

Installation Manual RADAR SENSOR MODEL DRS6A-NXT

(Product Name: SOLID STATE DOPPLER RADAR)

SAFETY INSTRUCTIONS	i
SYSTEM CONFIGURATION	iii
INSTALLATION SPECIFICATIONS.....	iv
FOREWORD.....	v
EQUIPMENT LISTS.....	vi
1. INSTALLATION AND WIRING.....	1
1.1 Mounting Considerations	1
1.2 Included Items.....	4
1.3 Required Tools and Materials	5
1.4 Fastening the Radiator to the Radiator Bracket.....	6
1.5 Mounting the Antenna Unit	8
1.6 Wiring.....	11
2. INITIAL SETUP.....	15
2.1 Initial Setup for TZT9/TZT14/TZTBB	16
2.2 Initial Setup for TZTL12F/TZTL15F	18
3. MAINTENANCE, TROUBLE SHOOTING.....	21
3.1 Maintenance	22
3.2 Troubleshooting	23
3.3 Replacement of Fuse.....	23
3.4 Life of Parts.....	24
APPENDIX 1 RADIO REGULATORY INFORMATION.....	AP-1
SPECIFICATIONS	SP-1
PACKING LIST	A-1
OUTLINE DRAWING	D-1
INTERCONNECTION DIAGRAM	S-1

NXT



 **FURUNO ELECTRIC CO., LTD.**

www.furuno.com

All brand and product names are trademarks, registered trademarks or service marks of their respective holders.



SAFETY INSTRUCTIONS

The installer of the equipment must read the safety instructions before attempting to install the equipment.

WARNING	Indicates a potentially hazardous situation which, if not avoided, can result in death or serious injury.
----------------	---

CAUTION	Indicates a potentially hazardous situation which, if not avoided, can result in minor or moderate injury.
----------------	--

Warning, Caution	Prohibitive Action	Mandatory Action
------------------	--------------------	------------------

WARNING
Do not open the equipment unless you are well familiar with electrical circuits. Only qualified personnel should work inside the equipment.
Do not disassemble or modify the equipment. Fire, electrical shock or serious injury can result.
Wear a safety belt and hard hat when working on the antenna unit. Serious injury or death can result if someone falls from the radar mast.
Construct a suitable service platform from which to install the antenna unit. Serious injury or death can result if someone falls from the radar mast.
Turn off the power at the switchboard before beginning the installation. Fire or electrical shock can result if the power is left on.

WARNING
Keep the objects away from the antenna unit, so as not to impede rotation of the antenna. Fire, electrical shock or serious injury can result.
Be sure that the power supply is compatible with the voltage rating of the equipment. Connection of an incorrect power supply can cause fire or damage the equipment.
Use only the specified power and signal cable. Fire or damage to the equipment can result if a different cable is used.
Use the proper fuse. Use of a wrong fuse can damage the equipment or cause fire.
Do not depend one navigation device for the navigation of the vessel. For the safety of vessel and crew, the navigator must check all aids available to confirm position.

⚠ WARNING

⚠ The radar antenna emits electromagnetic radio frequency (RF) energy which can be harmful, particularly to your eyes. Never look directly into the antenna aperture from a close distance while the radar is in operation or expose yourself to the transmitting antenna at a close distance.

Distances at which RF radiation levels of 100, 50 and 10 W/m² exist are given in the table below.

Radiator	100 W/m ²	50 W/m ²	10 W/m ²
XN10A	N/A	N/A	0.7 m
XN12A	N/A	N/A	0.6 m
XN13A	N/A	N/A	0.4 m

⚠ CAUTION

⚡ Ground the equipment to prevent mutual interference.

! It is recommended that you connect the antenna unit to a disconnecting device (circuit breaker, etc.) to control the power.

! Observe the following compass safe distances to prevent deviation of a magnetic compass:





Standard compass	Steering compass
0.70 m	0.40 m

🚫 Do not use high-pressure cleaners to clean this equipment.

This equipment has the waterproof rating outlined in the specifications, at the back of this manual. However, the use of high-pressure cleaning equipment can cause water ingress, resulting in damage to, or failure of, the equipment.

WARNING LABEL

A warning label is attached to the antenna unit. Do not remove the label. If the label is missing or damaged, contact your dealer about replacement.

 WARNING 	 警告 
To avoid electrical shock, do not remove cover. No user-serviceable parts inside.	感電の恐れあり。サービスマン以外の方はカバーを開けないで下さい。内部には高電圧部分が多いので、万ざさわると危険です。

Name: Warning Label (2)
 Type: 03-129-1001-3
 Code No: 100-236-743

Importer in Europe

The following concern acts as our importer in Europe, as defined in DECISION No 768/2008/EC.
 - Name: FURUNO EUROPE B.V.
 - Address: Ridderhaven 19B, 2984 BT Ridderkerk, The Netherlands

Program No.

- 0359423-01.**
- ** denotes minor modifications.

CE declarations

With regard to CE declarations, please refer to our website (www.furuno.com), for further information about RoHS conformity declarations.

SYSTEM CONFIGURATION

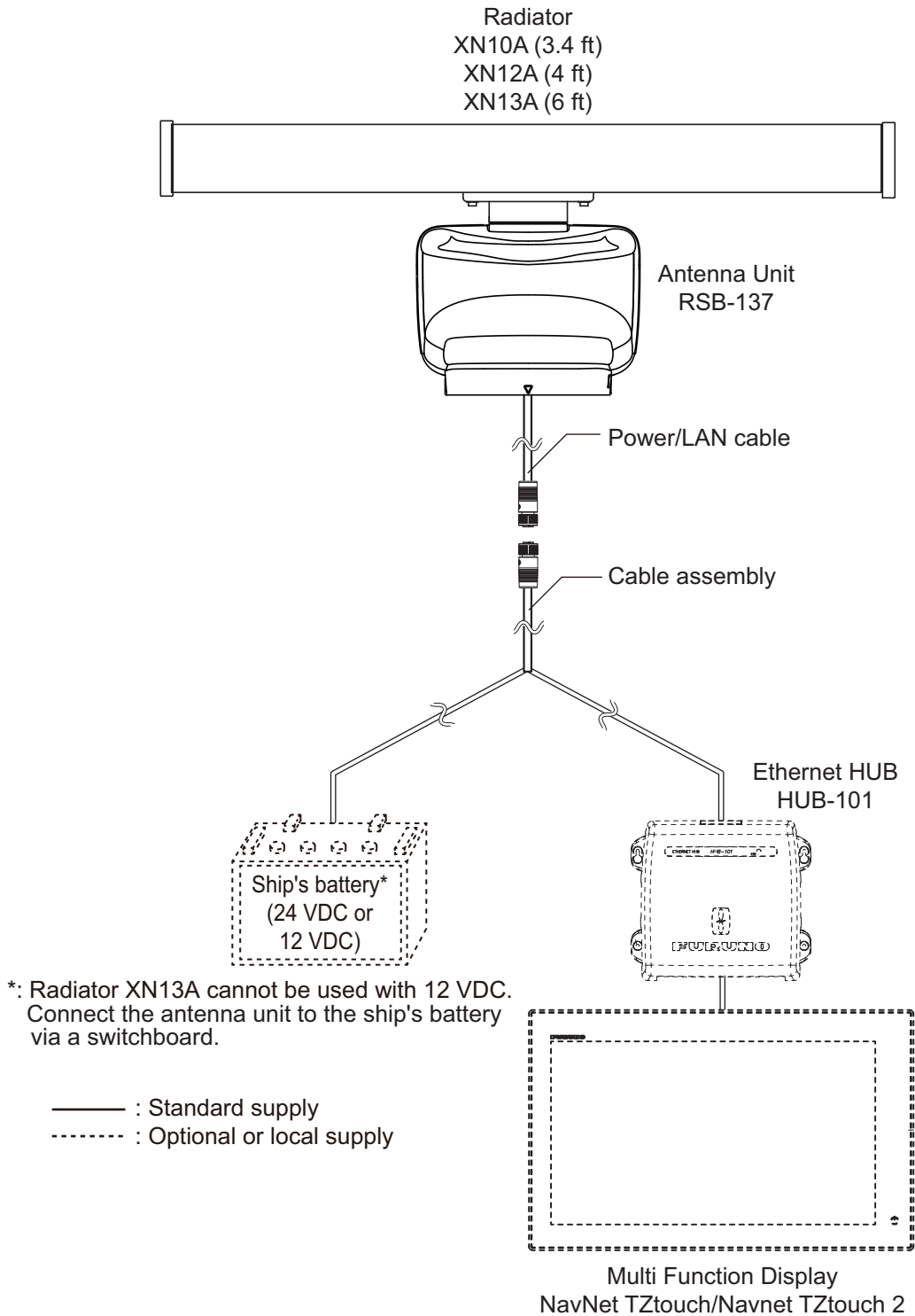

This radar series is compatible with the FURUNO Multi Function Displays and software version combinations shown below. The combination with other models or software versions may not operate properly.

- TZT9, TZT14 and TZTBB: Version 5.01 or later
- TZTL12F and TZTL15F: Version 5.01 or later

INSTALLATION SPECIFICATIONS

Voltage of Ship's Main and Usable Radiator

Supply Voltage	Radiator		
	XN10A	XN12A	XN13A
12 VDC	OK	OK	Not available
24 VDC	OK	OK	OK

Voltage of Ship's Main and Usable Cable Length

Supply Voltage	Cable Length			
	10 m	15 m	20 m	30 m
12 VDC	OK	Not available	Not available	Not available
24 VDC	OK	OK	OK	OK

Voltage of Ship's Main and Fuse to be used

Supply Voltage	Cable Length			
	10 m	15 m	20 m	30 m
12 VDC	15 A	Not available	Not available	Not available
24 VDC	10 A	10 A	10 A	10 A

Note: DO NOT USE 15 A fuse for 24 VDC. Use of a wrong fuse can damage the equipment or cause fire.

FOREWORD

A Word to the Owner of the DRS6A-NXT Marine Radar

Congratulations on your choice of the FURUNO DRS6A-NXT Marine Radar. We are confident you will see why the FURUNO name has become synonymous with quality and reliability.

Since 1948, FURUNO Electric Company has enjoyed an enviable reputation for innovative and dependable marine electronics equipment. This dedication to excellence is furthered by our extensive global network of agents and dealers.

Your equipment is designed and constructed to meet the rigorous demands of the marine environment. However, no machine can perform its intended function unless properly installed and maintained. Please carefully read and follow the operation and maintenance procedures set forth in this manual.

We would appreciate feedback from you, the end-user, about whether we are achieving our purposes.

Thank you for considering and purchasing FURUNO equipment.

Features

- TARGET ANALYZER* function displays targets which are moving and getting close to own ship in red, other targets in green and rain clutter in blue. Speed analyzing range is ± 50 kn.
* Requires a GPS sensor. When you change the setting of [Target Analyzer Mode] to [Rain], rain clutter is displayed.
- AUTO TARGET ACQUIRE function automatically acquires only the targets which are moving and getting close to own ship within the range of 3 NM by Doppler calculation. Automatic Doppler function will be activated when there is a target which approaches own ship with a speed of over 3 kn.
Note: The judged speed of target is dependent on its vector towards own ship.
- The azimuth resolution can be enhanced to as high as twice with using the RezBoost function.
Note 1: RezBoost function reflects the settings of [Antenna Length] which are introduced in page 17 and page 19.
Note 2: Refer to the Operator's Manual for your Multi Function Display regarding the above newfunctions.
- Instant ON function. This radar sensor does not have a magnetron, therefore preheating of the magnetron is unnecessary.
- Reduced electricity emission means no need to worry about the radiation hazard.
- Magnetron-less radar means no periodic replacement of magnetron or related parts.
- The maximum display range is 72 NM in the single range mode.
- ARPA (Automatic Radar Plotting Aid) function applicable range is 24 NM at the maximum.
- Dual Range Mode has the following limitations.
 - The maximum display range is 12 NM. (72 NM when single display)
 - The maximum detection range is reduced a maximum of 20% compared to the single display.

EQUIPMENT LISTS

Standard supply

Name	Type	Code No.	Qty	Remarks
Scanner Unit	RSB-137-119	-	1	
Radiator	XN10A	-	1	3.4 ft
	XN12A	-		4 ft
	XN13A	-		6 ft
Installation Materials	CP03-37101	001-426-290	1	For scanner unit
	CP03-22901	008-523-690	1	For radiator
	CP03-37700	000-033-452	1	Cable assembly (10 m)
	CP03-37710	000-033-453		Cable assembly (15 m)
	CP03-37720	000-033-454		Cable assembly (20 m)
	CP03-37730	000-033-455		Cable assembly (30 m)
Spare Parts	SP03-19101	000-477-060	1	Fuse (10 A and 15 A)

Optional supply

Name	Type	Code No.	Remarks
LAN Cable	MOD-Z072-020+	001-167-880-10	2 m
	MOD-Z072-050+	001-167-890-10	5 m
	MOD-Z072-100+	001-167-900-10	10 m
Joint Box	TL-CAT-012	000-167-140-10	For LAN cable extension

1. INSTALLATION AND WIRING

NOTICE

Do not apply paint, anti-corrosive sealant or contact spray to coating or plastic parts of the equipment.

Those items contain organic solvents that can damage coating and plastic parts, especially plastic connectors.

1.1 Mounting Considerations

Select a mounting location, keeping in mind the following points:

- Install the antenna unit on the hardtop, radar arch or on a mast on an appropriate platform.

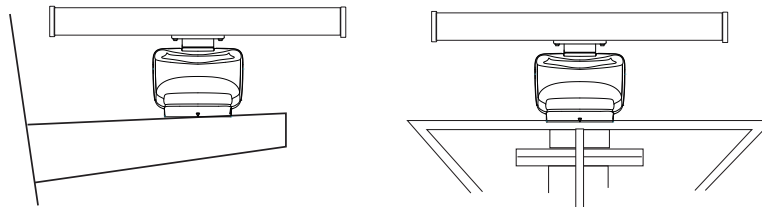

(a) Common mast

(b) Radar mast

- Locate the antenna where there is a good all-round view. Where possible, there should be no obstructions to the scanning beam such as superstructure or rigging. Obstructions cause shadow sectors and decrease the overall performance of the radar. The loss of performance can cause false echoes and reduce the quality of the observed images. A mast for instance, with a diameter considerably less than the horizontal beam width of the radiator, will cause only a small shadow sector. However, a horizontal spreader, or cross trees in the same horizontal plane as the antenna unit, would be a much more serious obstruction. You would need to place the antenna unit well above or below it. Be sure there are no metallic objects near the antenna.

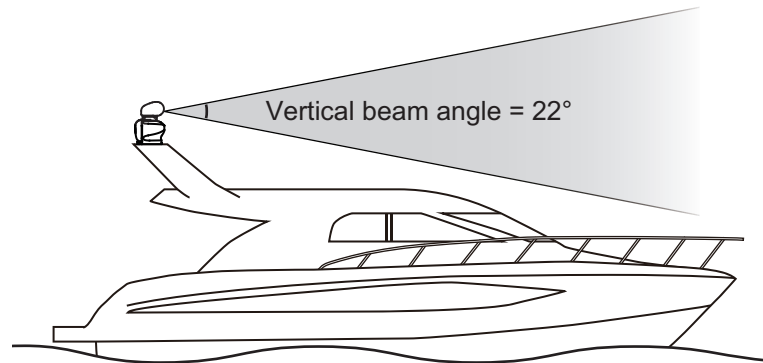

- It is rarely possible to place the antenna unit where a completely clear view in all directions is available. After fitting the antenna, determining any shadow sectors, their angle and bearing, and their influence on the radar is recommended.

1. INSTALLATION AND WIRING

- In order to reduce electrical interference, avoid routing the power cable near other electrical equipment on-board. Also, avoid running the cable in parallel with other power cables.
- It is not recommended to install the antenna unit on the hardtop of a cabin. Vibrations from the antenna unit will pass through the hardtop and into the cabin.

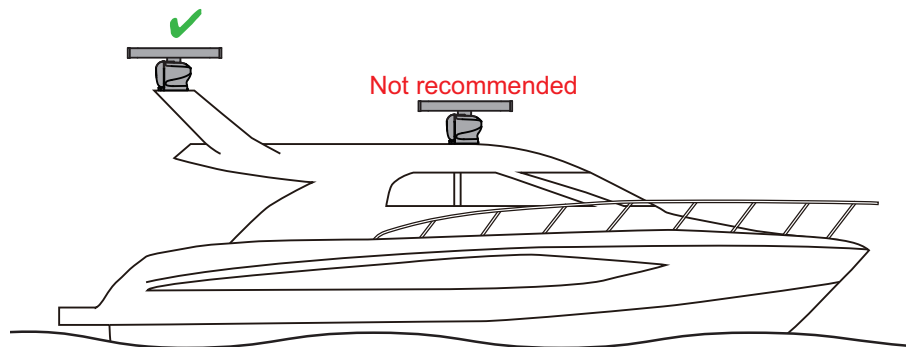

- Setup the antenna unit position on the FURUNO Multi Function Display after installing the unit, referring to chapter 2. If the antenna unit position is not setup correctly, the radar echoes on the display may not be aligned with the actual target's bearing.
- Select a location that does not allow water to accumulate at the installation location.
- A magnetic compass will be affected if the antenna unit is too close to the compass. Observe the compass safe distances mentioned in the SAFETY INSTRUCTIONS to prevent interference to a magnetic compass.
- To ensure proper emission of radar waves, do not paint the radiator.
- Referring to the outline drawings at the back of this manual, allow space for maintenance and service.
- When this antenna unit is to be installed on a large vessel, consider the following points:
 - The supplied cable assembly runs between the antenna unit and display (or ethernet HUB) and comes in lengths of 10 m, 15 m, 20 m or 30 m. Select the appropriate length when purchasing.
 - Deposits and fumes from a funnel or other exhaust vent can adversely affect the aerial performance and hot gases may distort the antenna unit. The antenna unit must not be mounted where the temperature is more than 55°C (131°F).

Consideration for selecting a location for installation (multiple radars)

- In case multiple radars are installed on a ship, DO NOT install the DRS6A-NXT within the range of the beam area emitted from other radar(s). Use the illustration below for reference when selecting a suitable location for installation. The Solid State Device (SSD) inside the DRS6A-NXT will be damaged if it is within the radar beam emission area from other radars.

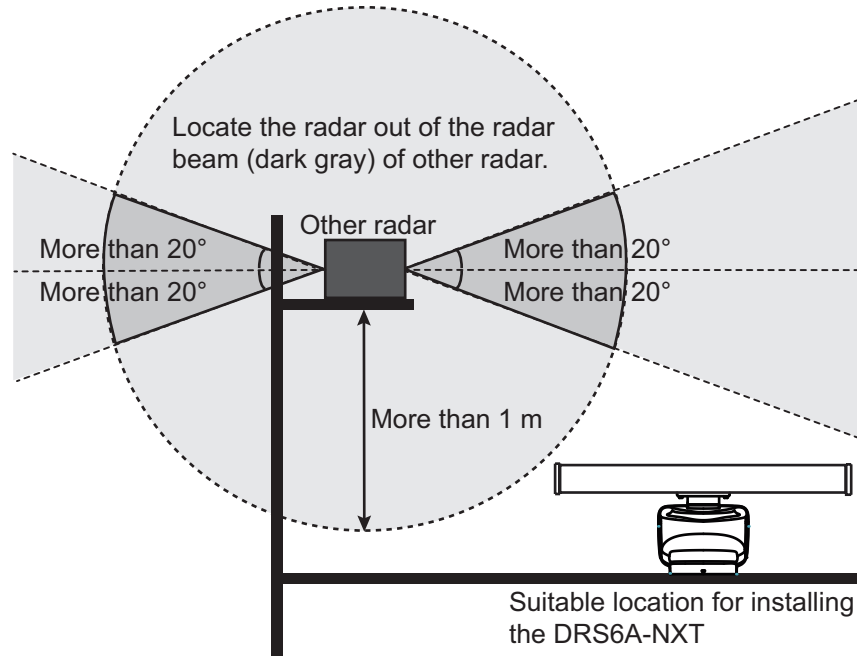
**Installation with the radiotelephone equipment**

- Install the open antenna away from radiocommunication antennas (SSB, VHF, Inmarsat) and GPS antennas to prevent radar interference.
- Install the open antenna away from the radiotelephone equipment so that electrical noise does not affect the radiotelephone equipment.

Cable routing

- In order to reduce the chance of picking up electrical interference, avoid, where possible, routing the power/LAN cable and cable assembly near other electrical equipment on-board. Also, avoid running the cable in parallel with other electrical cables.
- Make sure that the power/LAN cable does not run horizontally with the cable assembly and it is placed away from the cables carrying radio signal and antennas.

For large vessels

- When this radar sensor is to be installed on a large vessel, consider the following points:
 - The length of the pre-attached power/LAN cable is 1 m from the open antenna to the connector.
 - Deposits and fumes from a funnel or other exhaust vent can adversely affect the aerial performance and hot gases may distort the radiator portion. The radar sensor must not be mounted where the temperature is more than 55°C (131°F).

1.2 Included Items

Radiator

- Radiator* (1 pc):
3.4 ft, 4 ft or 6 ft
- Flat washer (M8, 4 pcs)
- Spring washer (M8, 4 pcs)
- Hex. bolt (M8×30, 4 pcs)
- O-ring (1 pc)
- Adhesive (1 pc)

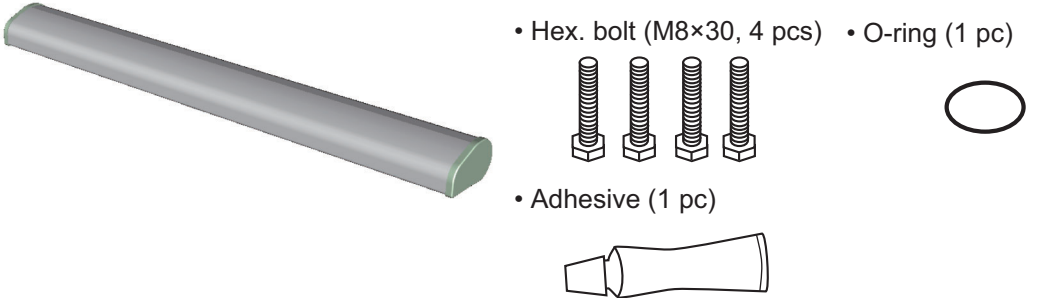

The radiator is a long, grey cylindrical tube. The hardware includes four flat washers, four spring washers, four hex bolts, one O-ring, and one tube of adhesive.

Scanner Unit

- Scanner Unit (1 pc)
- Flat washer (M12, 4 pcs)
- Spring washer (M12, 4 pcs)
- Hex nut (M12, 8 pcs)
- Insulation sheet (4 pcs)
- Stud bolt (M12×70, 4 pcs)
- Spare fuse (2 pcs)
(10 A and 15 A)
- Documents (1 set)

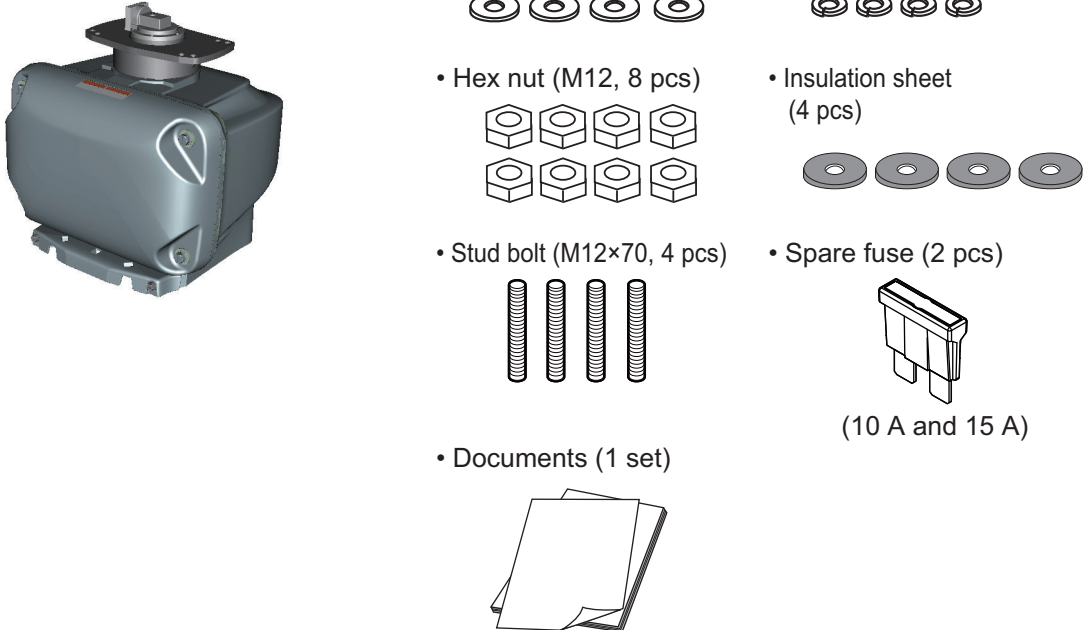

The scanner unit is a grey, rectangular device with a top-mounted sensor. The hardware includes four flat washers, four spring washers, eight hex nuts, four stud bolts, four insulation sheets, two fuses (one 10A and one 15A), and a set of documents.

Cable assembly

- Cable assembly* (1 pc):
10 m, 15 m, 20 m or 30 m
- Fuse for replacement
(For 10 m cable:
10 A and 15 A**
For other length cables:
10 A)
- Label
(For 10 m cable:
10 A and 15 A
For other length cables:
10 A)
- Document
How to Replace
the Fuse (1 pc)

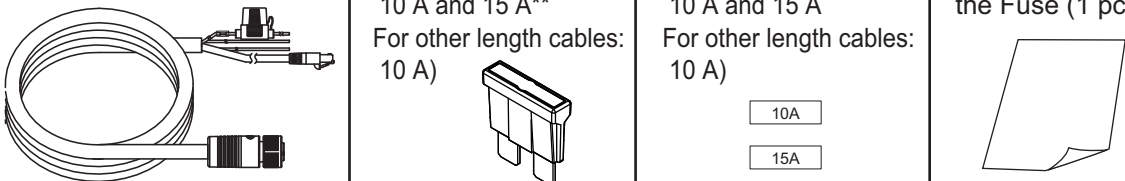

The cable assembly is a coiled cable with connectors. The fuse components include a fuse, a label, and a document. The label shows two options: 10A and 15A.

*: Select the appropriate length when purchasing.

** : Select the appropriate fuse according to ship' s main voltage.

1.3 Required Tools and Materials

The following tools should be prepared in advance for this installation.

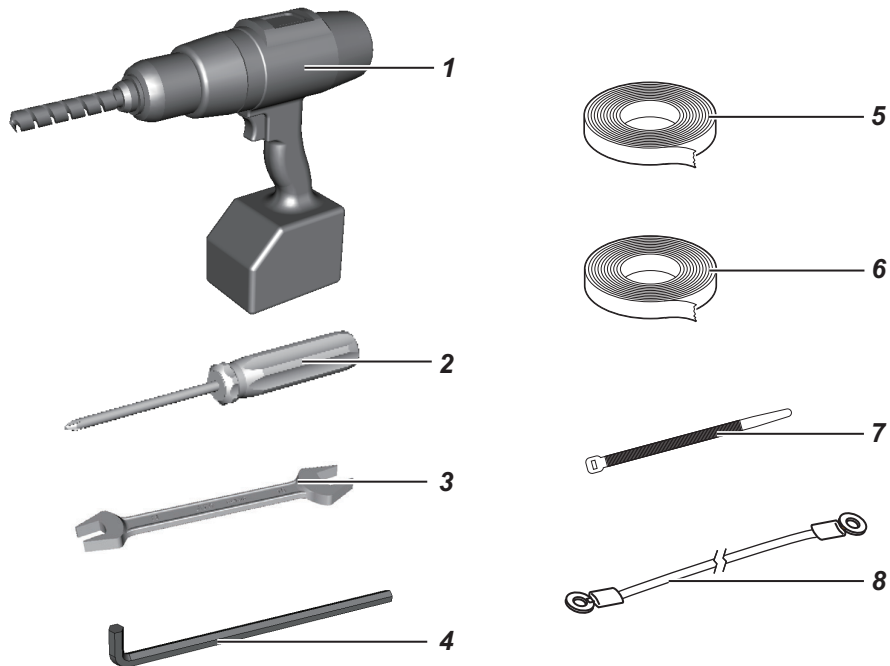

No.	Name	Remarks
1	Electrical drill	For making the mounting holes, drill bit: ϕ 15 mm
2	Phillips-head screw driver	#3, for securing the cable cover
3	Wrench	For M8 (Hex. size 13 mm) and M12 (Hex. size 19 mm)
4	Hex. L-wrench	For fastening the stud bolts (Hex. size 6 mm)
5	Self-vulcanizing tape	For waterproofing the junction of connectors
6	Vinyl tape*	
7	Cable tie	For securing the cables
8	Ground wire	IV-2sq

*: For cosmetic purposes, black color vinyl tape (cable color) is recommended.

1.4 Fastening the Radiator to the Radiator Bracket

1. Remove the radiator cap from the radiator bracket.

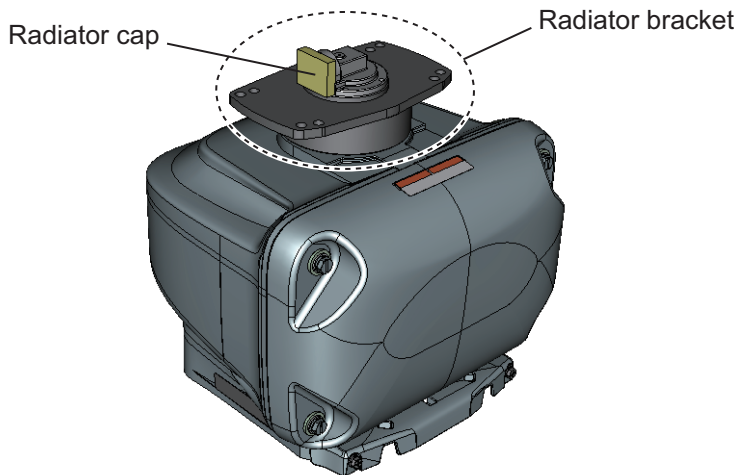

2. Apply adhesive to the surface of the radiator bracket as shown in the figure below.

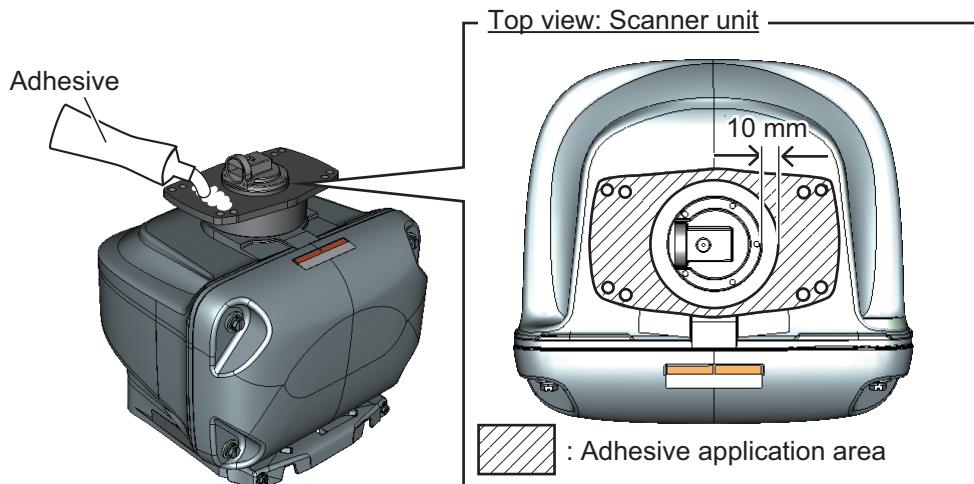

3. Set the O-ring to the radiator bracket.

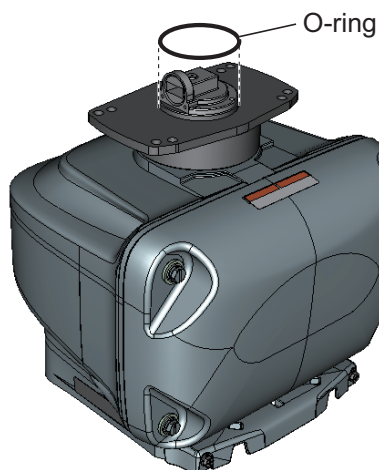

- Apply adhesive to the thread holes on the bottom of the radiator (4 locations).

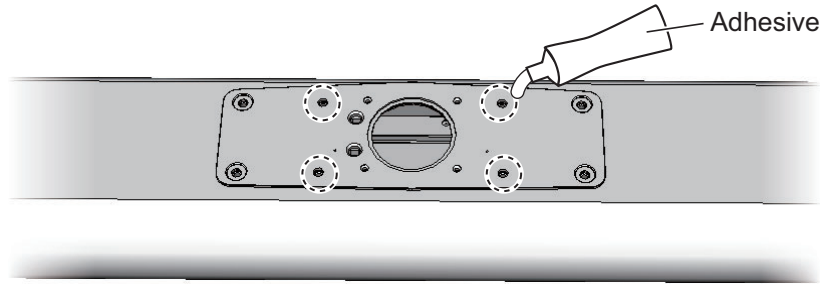

Bottom view: Radiator

- Prepare four bolt assemblies; pass the spring washer (M8) and flat washer (M8) through the each hex bolt (M8×30) then apply adhesive.

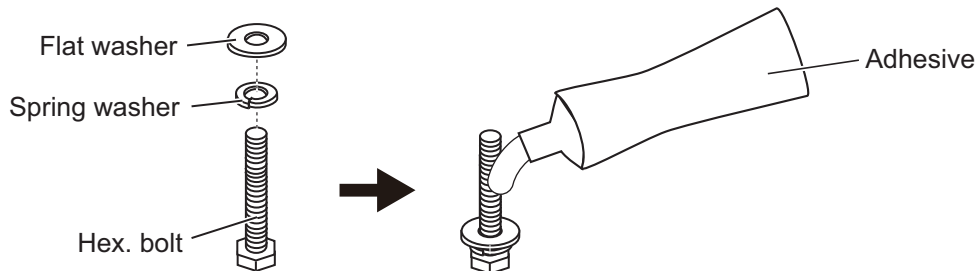

- Fasten the radiator to the radiator bracket, using the four bolt assemblies prepared at step 5.

Note: Be sure to align the waveguide location between the radiator and radiator bracket before fastening bolt assemblies.

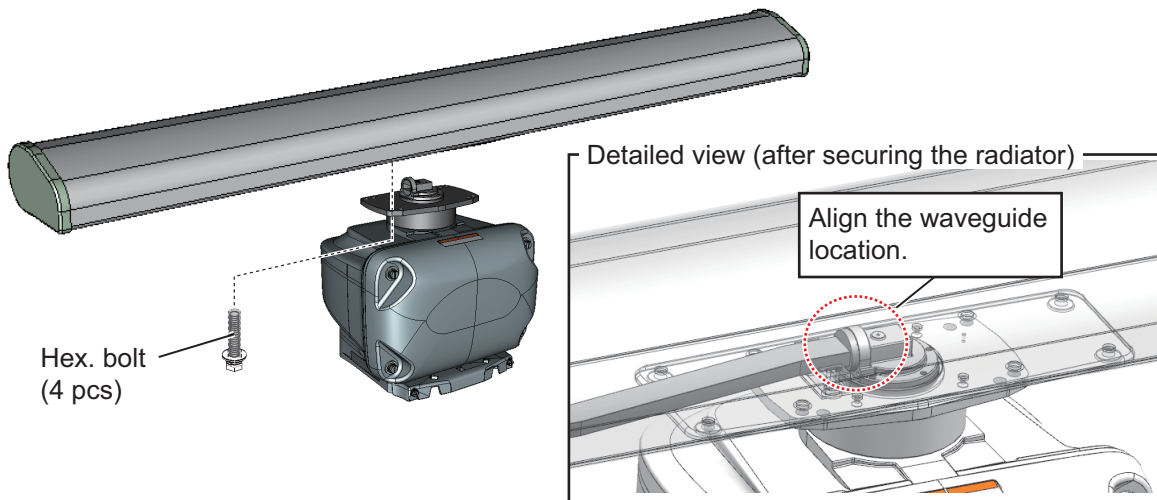

- Apply adhesive to the holes and bolts at the locations indicated with arrows in the figure below. Also apply adhesive to the junction between the radiator and the radiator bracket.

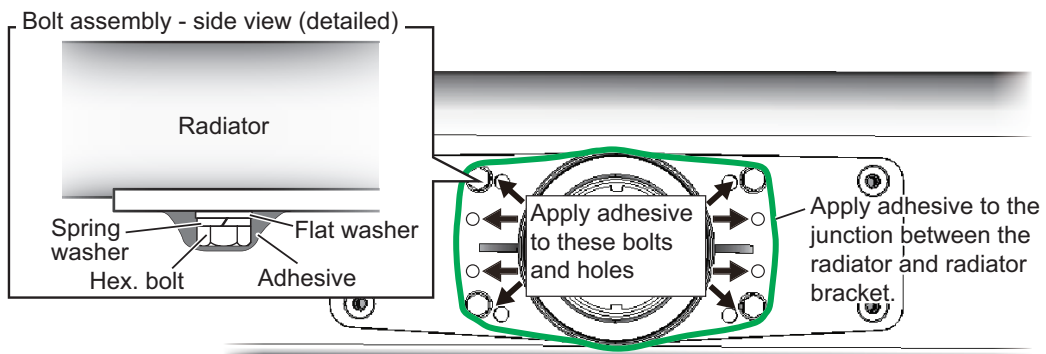

Radiator - bottom view

1.5 Mounting the Antenna Unit

The antenna unit can be mounted using the fixing holes on the outside (200 × 200 mm) or inside (140 × 150 mm) the antenna unit. Normally, use the outside fixing holes. When 140 × 150 mm fixing holes already exist on the mounting platform, use the inside fixing holes.

1. Set the supplied mounting template to the mounting location, then drill four fixing holes in the mounting location.

Note: The holes must be parallel with the fore and aft line.

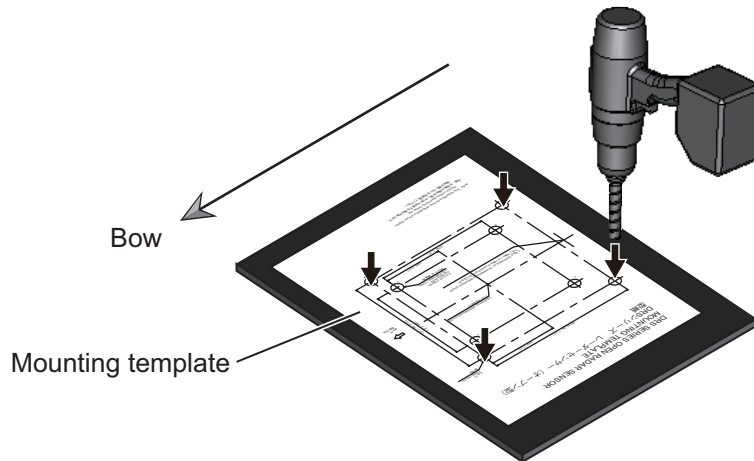

2. Apply adhesive to the thread of the stud bolts (M12×70, 4 pcs).
Note: Apply adhesive to the part of the bolt threads that are inside the bolt hole (see the figure at step 3).
3. Insert four stud bolts into the threaded holes in the antenna unit.
The stud bolts must make contact with the bottom of the threaded holes.
Note: Do NOT cover the vent hole at the bottom of the unit.

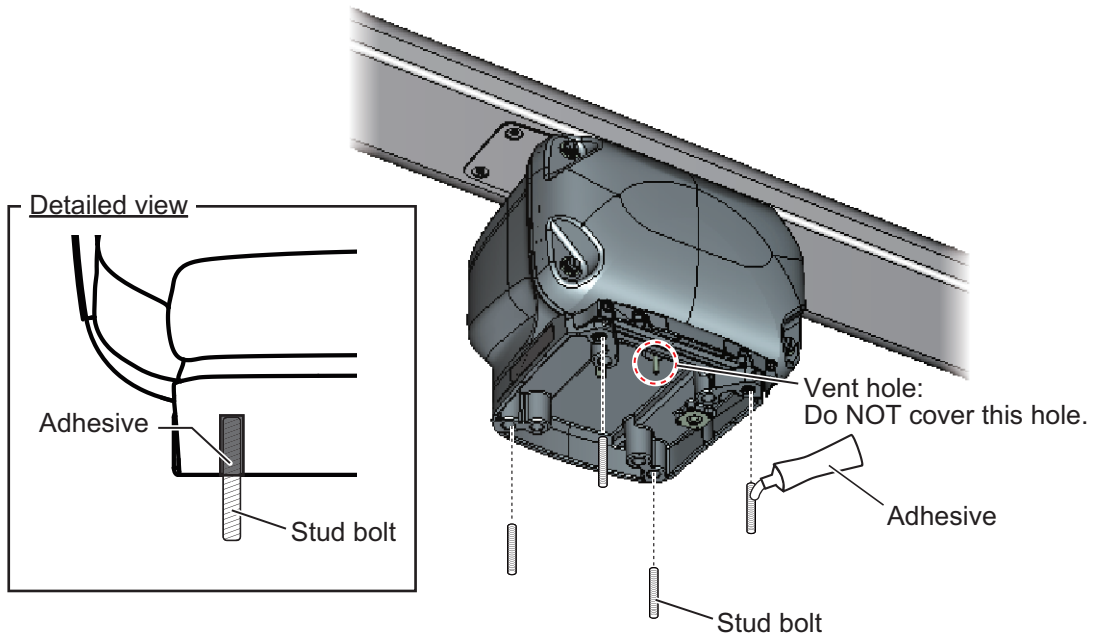

NOTICE

Do not fasten stud bolts tightly after the bolts contact with the bottom of the threaded holes.

If the bolts are fastened excessively, the chassis bottom may be damaged which can result in malfunction.

The projected bolt length after the bolts contact with the bottom of the threaded holes is approx. 50 mm. This data is for reference purpose only.

4. Apply adhesive around the base of the four stud bolts.
5. Set the insulation sheet (supplied) to the four stud bolts.

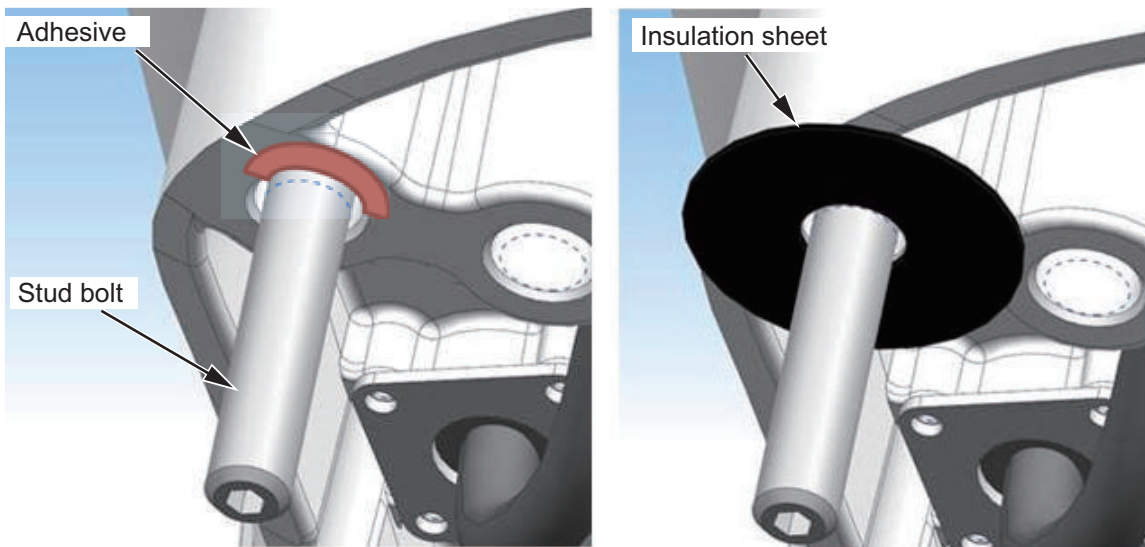

6. Hoist the antenna unit to the installation location, using two belt slings.
Note: When you hoist the antenna unit, keep in mind the following points:

1. INSTALLATION AND WIRING

- When you hoist the antenna unit, set two belt slings to the radiator bracket. Do not set the belt slings to the radiator, the radiator may get damaged.

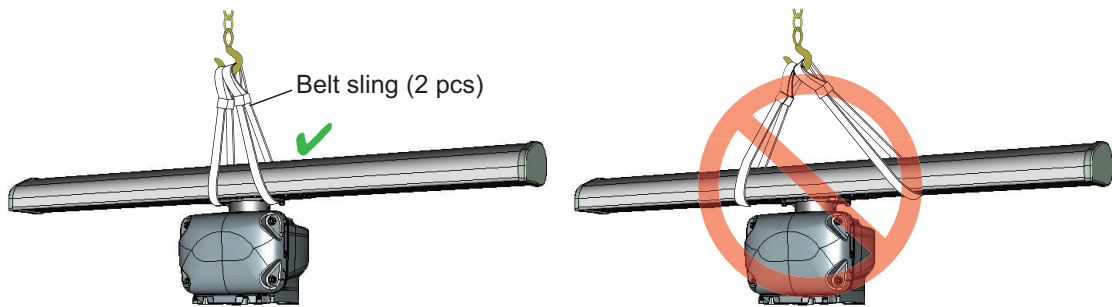

OK: Belt slings are set to the radiator bracket. **WRONG:** Belt slings are set to the radiator.

- Hoist the antenna unit slowly. If the antenna unit is hoisted too quickly, the bracket can be damaged.
7. Place the antenna unit on the mounting platform with the BOW mark on the unit aligned with the ship's bow.

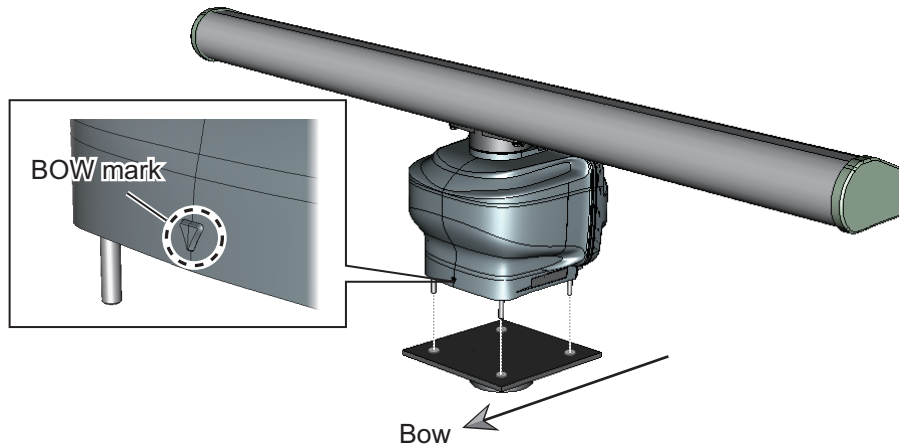

8. Secure the antenna unit, using the supplied flat washers (M12, 4 pcs), spring washers (M12, 4 pcs), and hex. nuts (M12, 8 pcs).

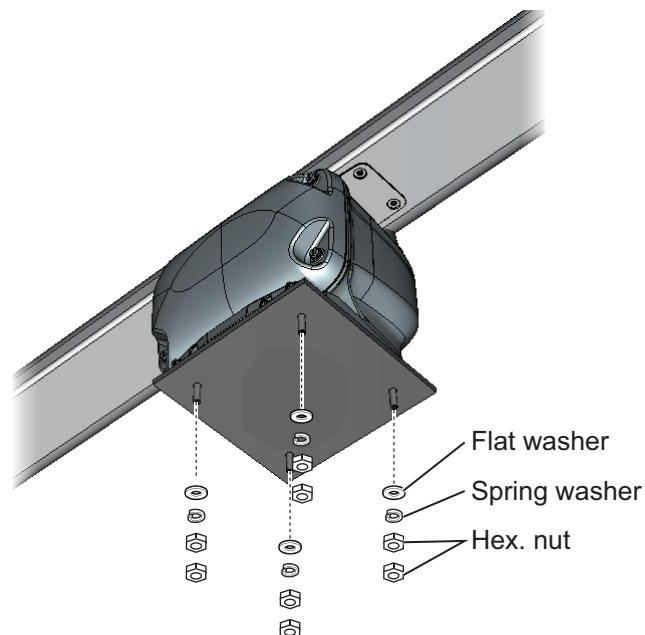

9. Apply adhesive to the flat washers, spring washers, and hex. nuts.

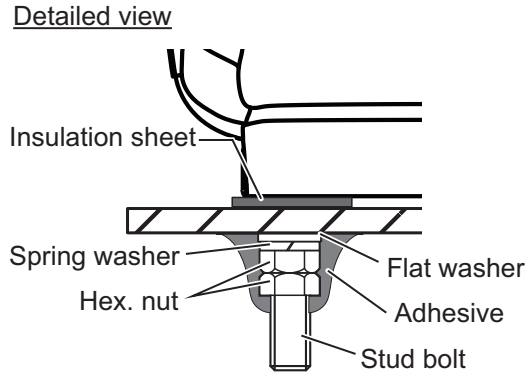

1.6 Wiring

Wiring considerations

- Turn the power at the switchboard off before beginning the wiring.
- The 5 A fuse in the fuse holder (supplied with the cable assembly) must be replaced with the supplied 10 A fuse when installing with 15 m, 20 m and 30 m cables. When installing with 10 m cables, the fuse to be used will be different according to the voltage of ship's main. Use the 15 A fuse for 12 VDC ship's main. Use the 10 A fuse for 24 VDC ship's main. Also, attach the supplied fuse rating label to the fuse holder. For details, see "How to Replace the Fuse" (C32-01604).
- The cable assembly and power/LAN cables have connector(s). Do NOT cut the cable assembly and power/LAN cables even if the cables are run through a radar mast.
- When you replace the DRS4A/6A/12A/25A with the DRS6A-NXT, the existing cable cannot be used. Use only the cable assembly supplied with this radar sensor.

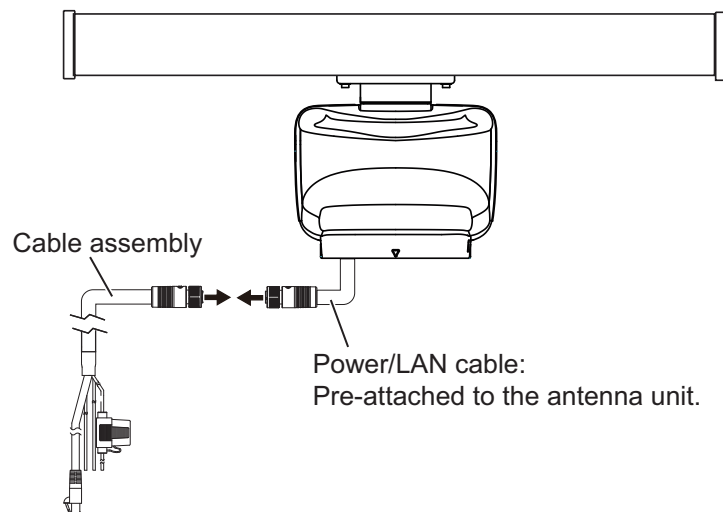

1. INSTALLATION AND WIRING

1. Unfasten two screws, circled in the following figure, to remove the cable cover.

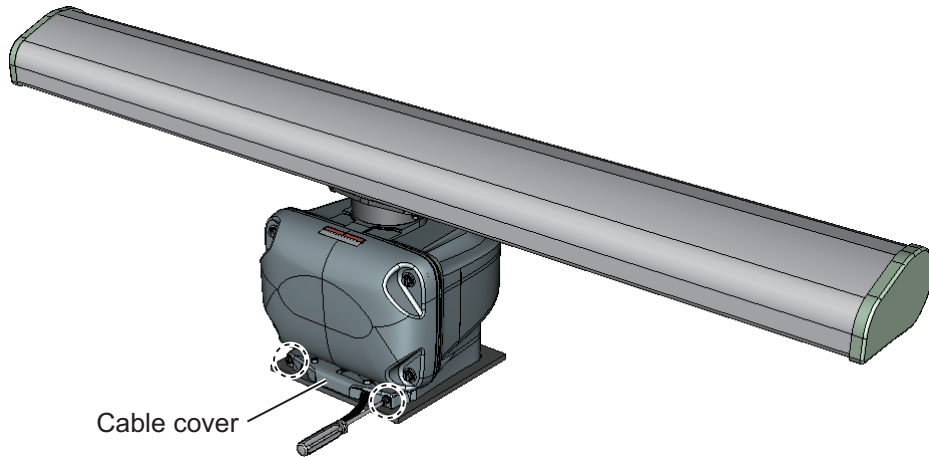

2. Connect the cable assembly (supplied) to the power/LAN cable that is pre-attached to the antenna unit.
3. Wrap the junction of the connectors with self-vulcanizing tape and vinyl tape (local supply) for waterproofing as follows:

- 1) Wrap the junction of the connectors with one layer of self-vulcanizing tape.

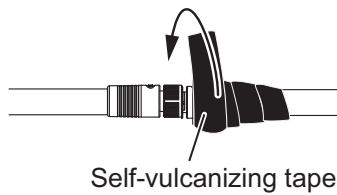

- 2) Change wrap direction and wrap one layer of the self-vulcanizing tape again.

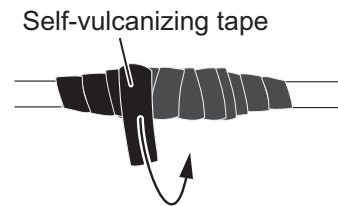

- 3) Wrap one layer of the vinyl tape over the self-vulcanizing tape.

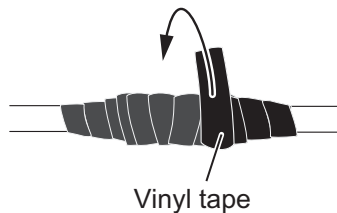

- 4) Change wrap direction and wrap one layer of the vinyl tape again.

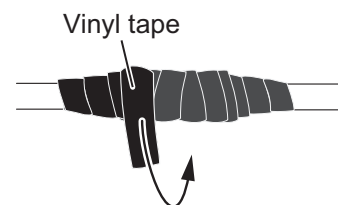

4. As shown in the figure below, secure the ground wire from the ship's ground (IV-2sq, local supply) and ground wire from the antenna unit, using the terminal screw (M4x10) that is pre-attached to the cable cover.

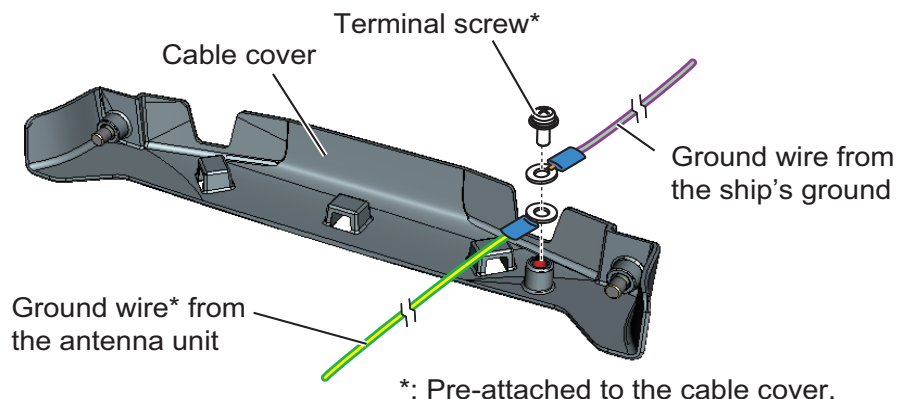

- Apply adhesive to the ground terminal after fastening the terminal screw.

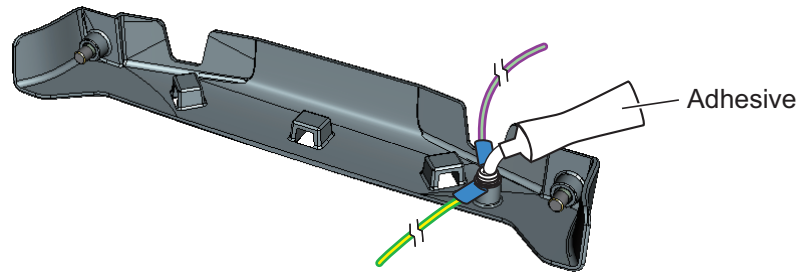

- Secure the ground wire to the ship's ground.
The figures shown below are examples for grounding.

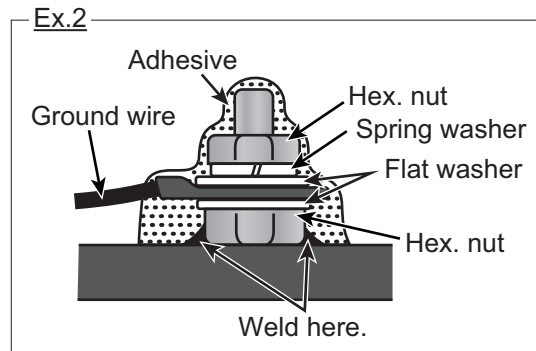
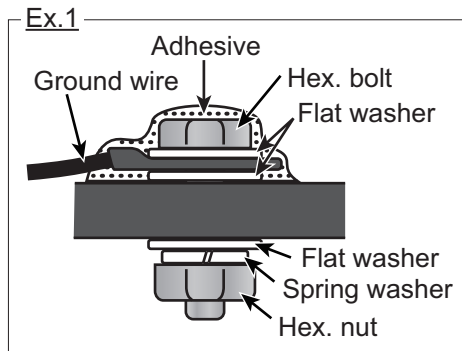

- Secure the cable assembly to the cable cover with the cable ties (local supply) as shown in the figure below.

If the cable is run through a radar mast and the bottom of the unit, fix the cable to this cable clamp.

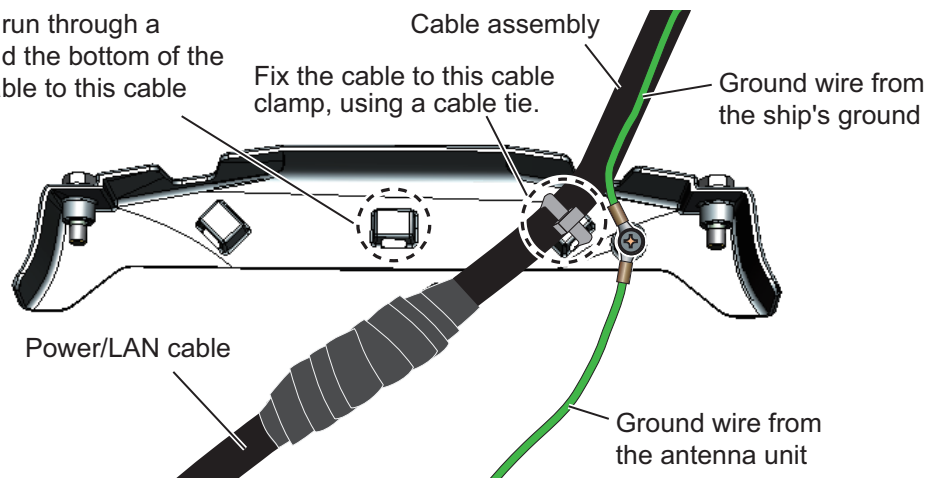

Cable cover - bottom view

- Reattach the cable cover.
- Connect the LAN connector of the cable assembly to a LAN port on the FURUNO Multi Function Display or Ethernet HUB.

Note 1: Do not connect the LAN connector to on-board LAN.

1. INSTALLATION AND WIRING

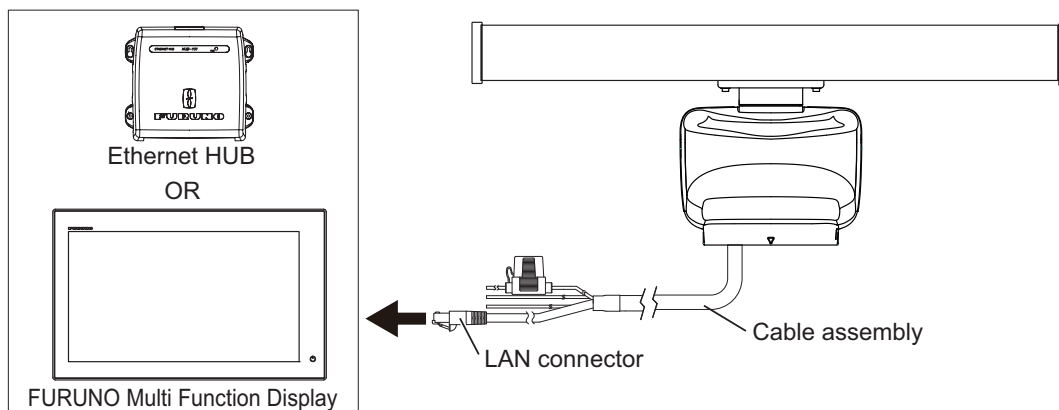

Note 2: When LAN cable extension is needed, use the optional LAN cable (MOD-Z072) and joint box (TL-CAT-012). After connection is completed, wrap the connector with vinyl tape to waterproof the LAN connector.

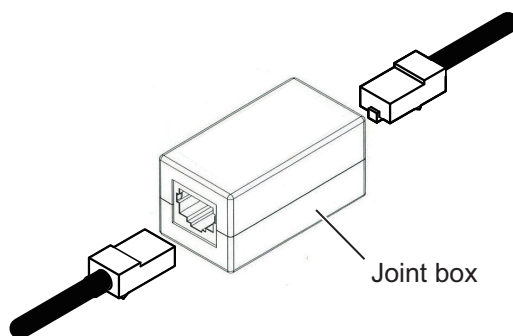

10. Connect the power wires to the ship's battery.
 - Red wire: Connect to the positive terminal. The red wire has the fuse holder.
 - Blue wire: Connect to the negative terminal.
 - Black wire: The black wire is a shielding wire for grounding.

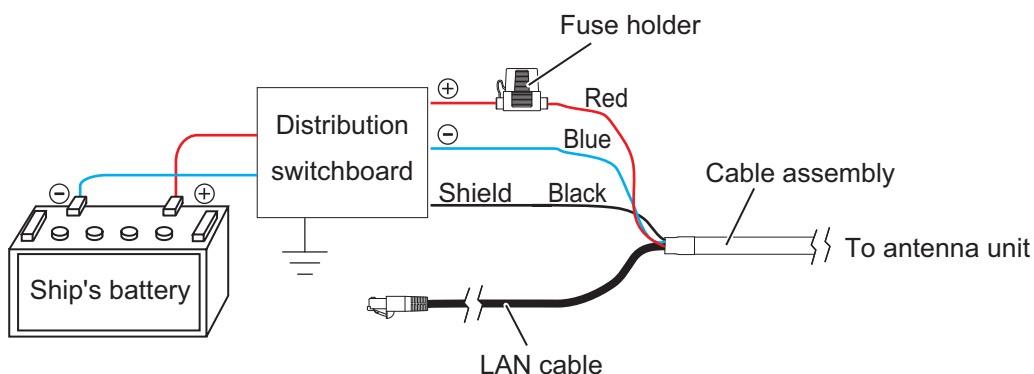

Note 1: The antenna unit has no power switch. Connect the antenna unit to a distribution switchboard with a switch for power control.

Note 2: The antenna unit cannot accept input voltage of more than 24 VDC.

Note 3: Power is supplied to the antenna unit even when the power is shut off at the display unit. If the radar is not to be used for an extended period, shut off the radar from the breaker.

2. INITIAL SETUP

⚠ WARNING

⚠ The radar antenna emits electromagnetic radio frequency (RF) energy which can be harmful, particularly to your eyes. **Never look directly into the antenna aperture from a close distance while the radar is in operation or expose yourself to the transmitting antenna at a close distance.**

Distances at which RF radiation levels of 100, 50 and 10 W/m² exist are given in the table below.

Radiator	100 W/m ²	50 W/m ²	10 W/m ²
XN10A	N/A	N/A	0.7 m
XN12A	N/A	N/A	0.6 m
XN13A	N/A	N/A	0.4 m

⚠ WARNING

⚠ Before turning on the radar, be sure no one is near the antenna.

Prevent the potential risk of being struck by the rotating antenna, which can result in serious injury or death.

Vessels equipped with SC-50/60/110/120

For better results when using the target analyzer function, an appropriate time need to be set in the [SMOOTH S/C] menu. When the time set in this menu is too long, the landmass can be judged as approaching target and displayed in red while accelerating, decelerating or turning. If this symptom occurs too often, shorten the time in [SMOOTH S/C] menu.

Note: Instability of COG and SOG can be larger when the [SMOOTH S/C] time becomes shorter. Set the time avoiding the influence to other navigational equipment, such as GPS plotter and autopilot.

Installation with Multi Function Displays

This radar series is compatible with the FURUNO Multi Function Displays and software version combinations shown below. Combination with other models may not operate properly.

- TZT9, TZT14 and TZTBB: Version 5.01 or later
TZTL12F and TZTL15F: Version 5.01 or later

Turn on the antenna unit and FURUNO Multi Function Display. Initial setup for this antenna must be done on the FURUNO Multi Function Display.

2.1 Initial Setup for TZT9/TZT14/TZTB

1. Press the **Home** key (or tap the **Home** icon).
2. Select [Menu] on the menu icon bar to open the main menu.
3. Select [Radar].
4. Select [Radar Source] on the [Menu Radar] sub menus, then select the radar type connected.

Note: If the antenna unit is connected but does not appear in the [Radar Source] list, close the list and open it again. The name of the antenna unit should appear with a check mark, as in the example to the right.



Display example

5. Drag the [Menu Radar] sub menus to find the menu item [Radar Initial Setup].

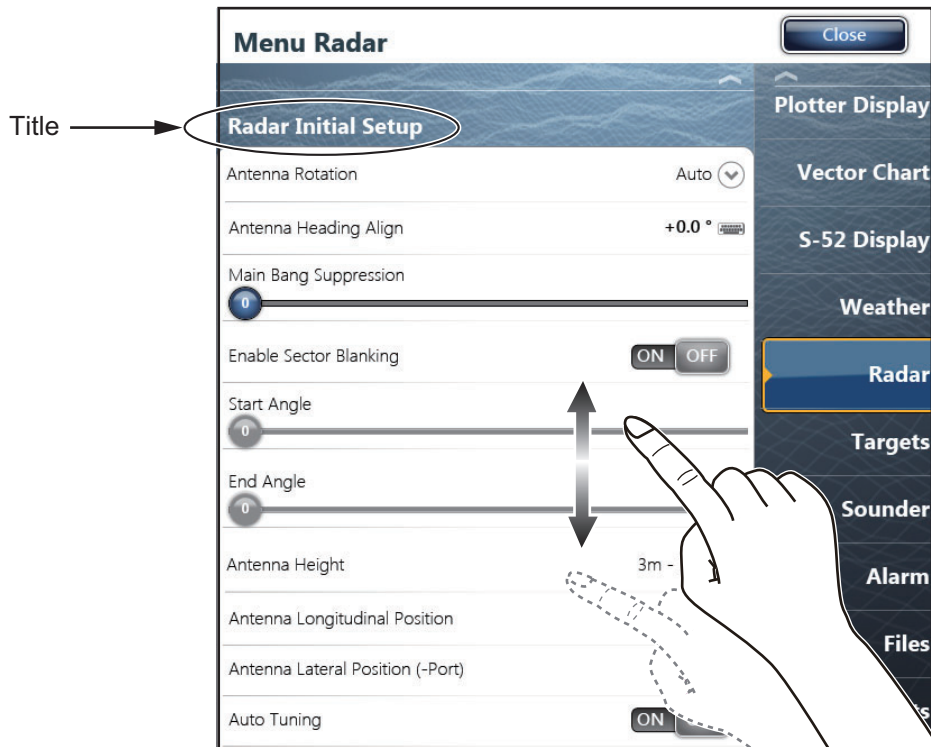

6. Set the items referring to the table shown below

Menu Radar (Radar Initial Setup)

Menu item	Description
[Antenna Rotation]	Select the antenna rotation speed.
[Antenna Heading Align]	See "How to align the antenna heading" on page 17.
[Main Bang Suppression]	If main bang appears at the screen center, slide the circle icon, while watching the radar echo on the left-side of the display, until the main bang disappears.
[Enable Sector Blanking]/ [Enable Sector Blanking2]	Up to two sectors may be selected for blanking (no transmission). Select [ON] to enable this feature. Set the start and end angles (0° to 359°).
[Antenna Height]	Select the height of the antenna above the waterline.

Menu item	Description
[Antenna Length]	Selects the length of the antenna. RezBoost function reflects the selection of this menu item.
[Antenna Longitudinal Position]	Referring to the figure on the right, enter the radar antenna positioning bow-stern (Longitudinal) and port-starboard (Lateral) position from the origin.
[Antenna Lateral Position (-Port)]	
[Radar Monitoring]	Display various information regarding the connected radar.
[ARPA Advanced Settings]	For service technician only. Do not change these settings. This menu item is available when setting the radar in transmit.
[TX Channel]	Select [1],[2] or [3], the channel where the interference is smallest.
[Target Analyzer Mode]	You can emphasize rain clutter or target echoes when the target analyzer is active. Select [Rain] or [Target] as appropriate.
[Auto Acquire by Doppler]	When selecting [ON], approaching targets within 3 NM from own ship are automatically acquired by the Doppler calculated from the radar echo.
[Hardware Factory Default]	Resets the radar selected at [Radar Source] to factory default.
[Reset Default Settings]	Resets [Radar] menu settings to default.



How to align the antenna heading

You have mounted the antenna unit facing straight ahead in the direction of the bow. Therefore, a small but conspicuous target dead ahead visually should appear on the heading line (zero degrees).

You may observe a minor bearing error on the display. This is due to the difficulty in orienting the radar accurately. The following adjustment will compensate for the error.

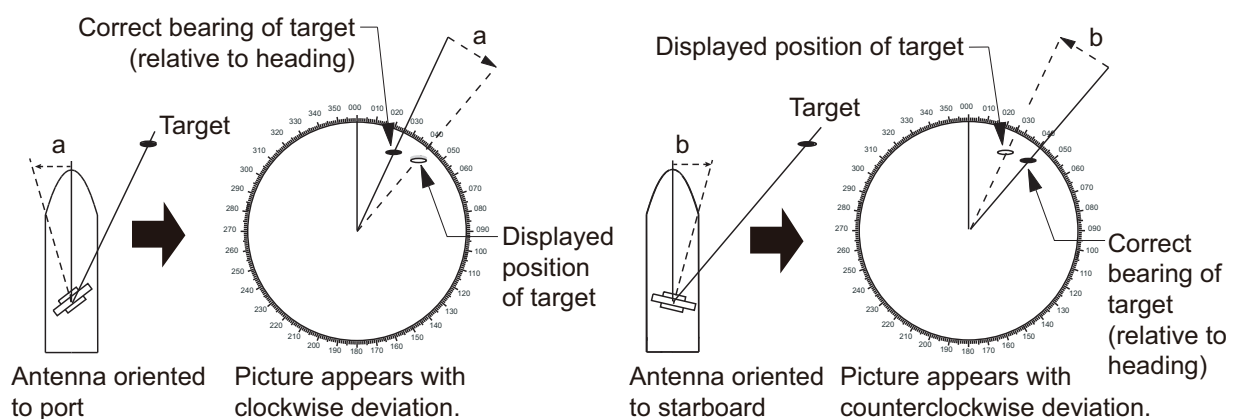

2. INITIAL SETUP

1. Select a range between 0.125 and 0.25 NM and set the mode to “head up”. You can select a range by a pinch action. The range and range ring interval appear at the bottom left of the screen.

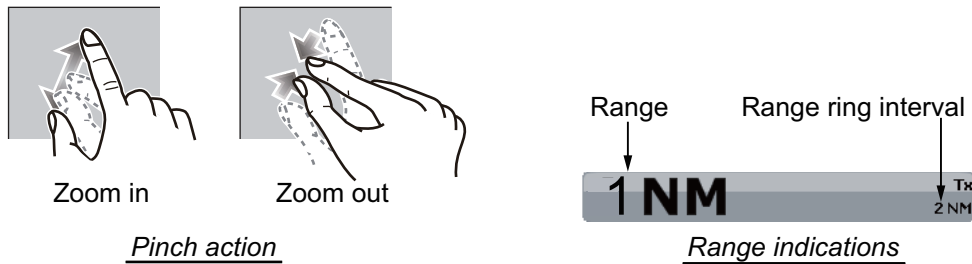

For TZTBB, you can also control the range in the operation as follows. Tap the radar scale box at the bottom left-hand corner of the screen to display the slider bar. Drag the circle icon to set the range scale.

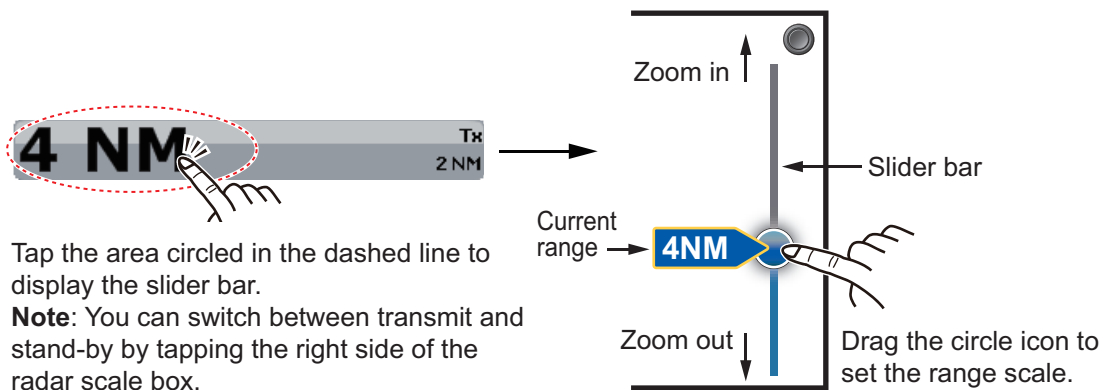

Tap the area circled in the dashed line to display the slider bar.

Note: You can switch between transmit and stand-by by tapping the right side of the radar scale box.

2. Turn the vessel's bow toward a target.
3. Press the **Home** key (or tap the **Home** icon), then select [Menu] icon, [Radar], and [Antenna Heading Align] in that order to show the numeric software keyboard.
4. Key in the offset value so that the target is at the very top of the screen (setting range: +/- 0° to 180°, +: clockwise direction, -: counterclockwise direction), then tap [Save].
5. Confirm that the target echo is displayed at correct bearing on the screen.

2.2 Initial Setup for TZTL12F/TZTL15F

1. Tap the [Home] icon to show the home screen and display mode settings.
2. Tap [Radar] from the [Settings] menu.
3. Tap [Radar Source], then select the appropriate antenna unit.
Note: If the antenna unit is connected but does not appear in the [Radar Source] list, close the list and open it again. The name of the antenna unit should appear with a check mark, as in the example below.

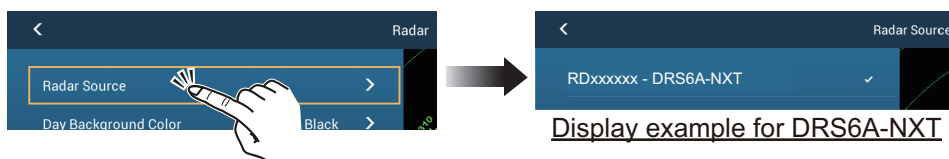

4. Drag the [Radar] menu display the menu item [Radar Initial Setup], then tap [Radar Initial Setup].
5. Referring to the tables below, set up the radar.

[Radar] menu - [Radar Initial Setup]

Menu item	Description
[Antenna Rotation]	Select the antenna rotation speed.
[Antenna Heading Align]	See "How to align the antenna heading" on page 19.
[Main Bang Suppression]	If main bang appears at the screen center, slide the circle icon so that the main bang disappears, while watching the radar echo at the left-hand side of the display.
[Enable Sector Blanking]	Up to two sectors may be selected for blanking (no transmission). Select [ON] to enable this feature. Set the start and end angles (0° to 359°).
[Enable Sector 2 Blanking]	

[Radar] menu - [Antenna Position]

Menu item	Description
[Longitudinal (from bow)] [Lateral (-Port)]	Referring to the figure on the right, enter the radar antenna positioning bow-stern (Longitudinal) and port-starboard (Lateral) position from the origin. 
[Antenna Height]	Selects the height of the antenna above the waterline.
[Antenna Length]	Selects the length of the antenna. RezBoost function reflects the selection of this menu item.
[Radar Monitoring]	Display various information regarding the connected radar.
[TX Channel]	Select [1], [2] or [3], the channel where the interference is smallest.
[Target Analyzer Mode]	You can emphasize rain clutter or target echoes when the target analyzer is active. Select [Rain] or [Target] as appropriate.
[Auto acquire by Doppler]	When selecting [ON], approaching targets within 3 NM from own ship are automatically acquired by the Doppler calculated from the radar echo.
[Set Hardware To Factory Default]	Resets the radar selected at [Radar Source] to factory default.
[Reset Default Settings]	Resets [Radar] menu settings to default.

How to align the antenna heading

You have mounted the antenna unit facing straight ahead in the direction of the bow. Therefore, a small but conspicuous target dead ahead visually should appear on the heading line (zero degrees).

You may observe a minor bearing error on the display. This is due to the difficulty in orienting the radar accurately. The following adjustment will compensate for the error.

2. INITIAL SETUP

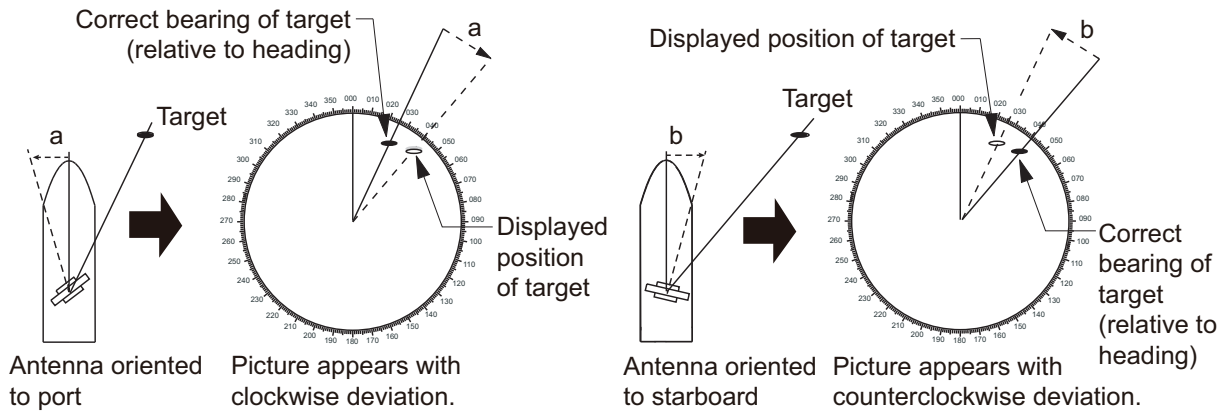

1. Set your radar with 0.125 and 0.25 NM range and the head up mode. The range scale can be selected two ways, as shown below. The slider bar can be shown or hidden with [Show Scale Slider] in the [Settings] - [Radar] menu.

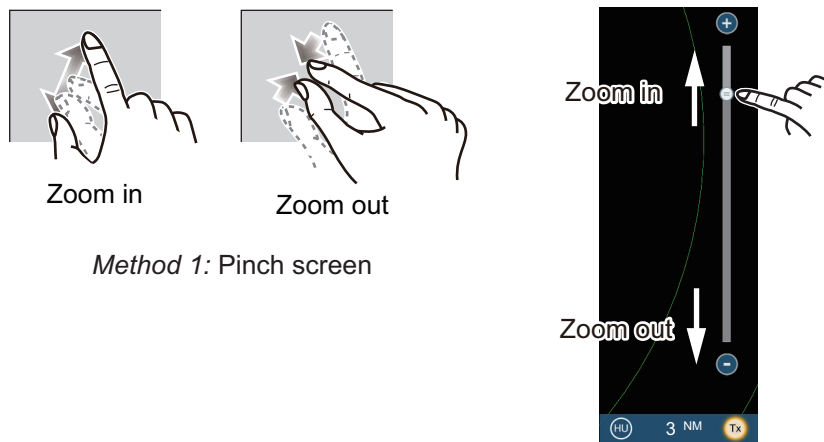





Method 2: Drag slider
(or tap bar or +, - icons)

2. Turn the vessel's bow toward a target.
3. Tap the [Home] icon to show the home screen and display mode settings.
4. Tap [Radar] to show the [Radar] menu.
5. Drag the [Radar] menu to show the [RADAR INITIAL SETUP] menu.
6. Tap [Antenna Heading Align].
7. Key in the offset value so that the target is displayed at the very top of the screen (setting range: $+179.9^\circ$ to -180° , +: clockwise direction, -: counterclockwise direction), then tap the .
8. Confirm that the target echo is displayed at correct bearing on the screen.

3. MAINTENANCE, TROUBLE SHOOTING

Periodic checks and maintenance are important for proper operation of any electronic system. This chapter contains maintenance and troubleshooting instructions to be followed to obtain optimum performance and the longest possible life of the equipment. Before attempting any maintenance or troubleshooting procedure, please review the safety information below and at the front of this manual. If you cannot restore normal operation after following the troubleshooting procedures, do not attempt to check inside any unit; there are no user serviceable parts inside. Contact your dealer to check the equipment.

 WARNING	
	<p>Do not open the equipment.</p> <p>Hazardous voltage which can cause electrical shock exists inside the equipment. Only qualified personnel should work inside the equipment.</p>
	<p>Turn off the antenna unit before servicing the unit. Post a warning sign near the switch indicating it should not be turned on while the antenna unit is being serviced.</p> <p>Prevent the potential risk of being struck by the rotating antenna.</p>
	<p>A transmitting radar antenna emits electromagnetic waves, which can be harmful, particularly the eyes.</p>
	<p>Wear a safety belt and hard hat when working on the antenna unit.</p> <p>Serious injury or death can result if someone falls from the radar antenna mast.</p>

NOTICE
<p>Do not apply paint, anti-corrosive sealant or contact spray to coating or plastic parts of the equipment.</p> <p>Those items contain organic solvents that can damage coating and plastic parts, especially plastic connectors.</p>

3.1 Maintenance

Regular maintenance is important for good performance. Check the points mentioned below every 3 to 6 months to keep the antenna unit in good working order.

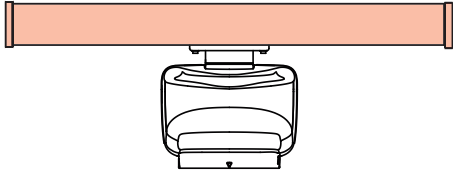
Check point	Action	Remedy, remarks
Check points every 3 to 6 months		
Cable	Check that all cables are firmly connected and are not damaged.	<ul style="list-style-type: none"> • Connect a cable if it has loosened. • Replace damaged cables.
Exposed bolts and nuts	Check that bolts and nuts are not corroded and are securely fastened.	<ul style="list-style-type: none"> • Replace corroded bolts. • Tighten loosened bolts. • Coat new bolts with adhesive.
Radiator	Dust, dirt and salt deposits on the radiator cause signal attenuation, resulting in loss of sensitivity.	<ul style="list-style-type: none"> • Wipe radiator with a freshwater-moistened cloth. • The radiator is made of AES (Acrylonitrile-Ethylene-Styrene) resin. Therefore, do not use gasoline, benzene and the like to clean the radiator. • If the radiator is iced, use a wooden or plastic headed hammer to remove the ice. DO NOT use a steel hammer.
Ground connection	Check for tight connection and rust.	<ul style="list-style-type: none"> • Fasten if loosened. • Remove rust if present.
Check points every year		
	Check the scanner unit for rust, corrosion and chipped paint.	<ul style="list-style-type: none"> • If the scanner unit has rusted or the paint has chipped, paint the affected area of the scanner unit. • Do not paint the antenna (see figure below). Paint on the antenna can cause loss of sensitivity and crack the antenna.  <p> : Do NOT paint. : Painting area </p>

3.2 Troubleshooting

The table below provides simple troubleshooting procedures to restore normal operation. If you cannot restore normal operation, contact your dealer for advice.

Problem	Remedy
The multi function display cannot control the radar.	<ul style="list-style-type: none"> • Check that all cables are tightly fastened. • Check if the radar source setting is correct. • Check if the fuse of the cable assembly has blown. • Check that the power supply is compatible with the voltage rating of the antenna unit.
Marks and characters appear, but echoes do not appear.	<ul style="list-style-type: none"> • Check that the antenna cable is tightly fastened. • Check the cables for damage.
Picture is not updated or the picture freezes.	<ul style="list-style-type: none"> • Check that all cables are tightly fastened. • Check the cables for damage. • If the picture has frozen, reboot the multi function display.
You changed the range, but the radar picture does not change.	<ul style="list-style-type: none"> • Try to change the range again. • Reboot the multi function display.
Poor discrimination in range.	<ul style="list-style-type: none"> • Adjust the sea control.
Range rings are not displayed.	<ul style="list-style-type: none"> • Check if the range rings is turned on in the menu.
You set the radar in the transmit state. The "TX screen" appears momentarily, but the radar soon goes into stand-by.	<ul style="list-style-type: none"> • The overload protection has activated. To restore normal operation, turn off all equipment in the network. Wait a few seconds then turn on all the equipment.

3.3 Replacement of Fuse

The fuse in the fuse holder on the supplied cable assembly protects the antenna unit from overcurrent and equipment fault. If you cannot turn on the power, check the fuse to see if it has blown. If the fuse has blown, find the reason before you replace the fuse. If the fuse blows again after the replacement, contact your dealer.

Name	Type	Code No.	Remarks
Fuse	ATV10A60V	000-192-660-10	10 A fuse For 24 VDC Ship's Main
	ATV15A60V	000-193-631-10	15 A fuse For 12 VDC Ship's Main

⚠ WARNING

! **Use the proper fuse.**
Use of a wrong fuse can cause fire or damage the equipment.

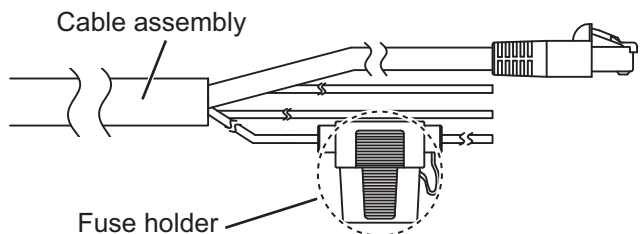

How to replace the fuse

Open the fuse holder cover and replace the fuse. Then close the cover.

3.4 Life of Parts

Antenna Motor

When an antenna motor reaches the end of its life, the antenna's rotation may stop or abnormal noise sounds from the antenna unit. If such symptom occurs, contact your dealer about replacement of the antenna motor.

Name	Type	Code No.	Approx. Life
Antenna Motor	RSB-134/137 MOTOR	001-426-690	10,000 hours

APPENDIX 1 RADIO REGULATORY INFORMATION

USA-Federal Communications Commission (FCC)

This device complies with part 15 of the FCC Rules. Operation is subject to the following two conditions:

- (1) This device may not cause harmful interference, and
- (2) This device must accept any interference received, including interference that may cause undesired operation. Any changes or modifications not expressly approved by the party responsible for compliance could void the user's authority to operate the equipment.

Caution: Exposure to Radio Frequency Radiation

- This equipment complies with FCC radiation exposure limits set forth for an uncontrolled environment and meets the FCC radio frequency (RF) Exposure Guidelines in Supplement C to OET65.
- This equipment should be installed and operated keeping the radiator at least 70 cm or more away from person's body.

Antenna Models	Safety Distance
XN10A	0.7 m
XN12A	0.6 m
XN13A	0.4 m

- This device must not be co-located or operating in conjunction with any other antenna or transmitter.

Canada-Industry Canada (IC)

Caution: Exposure to Radio Frequency Radiation

This equipment complies with IC radiation exposure limits set forth for an uncontrolled environment and meets RSS-102 of the IC radio frequency (RF) Exposure rules. This equipment should be installed and operated keeping the radiator at least 70 cm or more away from person's body.

Antenna Models	Safety Distance
XN10A	0.7 m
XN12A	0.6 m
XN13A	0.4 m

Cet équipement est conforme aux limites d'exposition aux rayonnements énoncées pour un environnement non contrôlé et respecte les règles d'exposition aux fréquences radioélectriques (RF) CNR-102 de l'IC. Cet équipement doit être installé et utilisé en gardant une distance de 70 cm ou plus entre le dispositif rayonnant et le corps.

To reduce potential radio interference to other users, the antenna type and its gain should be so chosen that the equivalent isotropically radiated power (EIRP) is not more than that required for successful communication.

SPECIFICATIONS OF RADAR SENSOR DRS6A-NXT

1 ANTENNA UNIT

- 1.1 Antenna type Slotted waveguide array
- 1.2 Antenna length 3.4 ft (XN10A), 4 ft (XN12A), 6 ft (XN13A)
- 1.3 Horizontal beam width 2.3° (XN10A), 1.9° (XN12A), 1.35° (XN13A)
 RezBoost effective beam width*
 1.15° to 2.3° (XN10A), 0.95° to 1.9° (XN12A), 0.7° to 1.35° (XN13A)
- *: RezBoost provides better echo resolution, in a manner similar to adjusting the beam width.
- 1.4 Vertical beam width 22°
- 1.5 Gain 27.5 dBi (XN10A), 28.5 dBi (XN12A), 30 dBi (XN13A)
- 1.6 Sidelobe attenuation
 XN10A -20 dB (within ±10°), -28 dB (±10° or more)
 XN12A -27 dB (within ±10°), -34 dB (±10° or more)
 XN13A -29 dB (within ±10°), -37 dB (±10° or more)
- 1.7 Rotation 24/36/48 rpm range coupled or 24 rpm fixed
- 1.8 Relative wind load 70 kn or less

2 RADAR FUNCTION

- 2.1 Tx frequency 3 channel, auto/manual selectable
 Ch.1 (P0N/Q0N) 9380/9400 MHz
 Ch.2 (P0N/Q0N) 9400/9420 MHz
 Ch.3 (P0N/Q0N) 9420/9440 MHz
- 2.2 Output power 25 W
- 2.3 Duplexer Ferrite circulator with diode limiter
- 2.4 Intermediate frequency 83.75/103.75 MHz (P0N/Q0N)
- 2.5 Range, Pulse length and Pulse Repetition Rate (PRR)

Range (NM)	Pulse length [P0N/Q0N] (μs)	PRR (Hz. approx.)
0.0625	0.04/5.0	2000
0.125 to 0.75	0.08/5.0	2000
1 to 1.5	0.15/7.5	2000
2	0.3/11	2000
3 to 4	0.5/13	2000
6 to 8	0.8/15	1100
12 to 24	1.2/18	1100
32 to 72	1.2/48	700

- 2.6 Minimum range 10 m
- 2.7 Range resolution 10 m
- 2.8 Range accuracy Within 1% of range in use
- 2.9 Bearing accuracy Within ±1°
- 2.10 Warm-up time Nil
- 2.11 Target tracking (TT) Auto or manual acquisition: 100 targets between 0.1 and 24 NM
 Past position: 5/10 pts on all activated targets
 Vector time: 1 to 60 min.

3 INTERFACE

LAN: 1 port, Ethernet, 100Base-TX

4 POWER SUPPLY

12/24 VDC: 9.5/5.0 A max.

5 ENVIRONMENTAL CONDITIONS

5.1 Ambient temperature -25°C to +55°C (storage: -30°C to +70°C)

5.2 Relative humidity 95% or less at +40°C

5.3 Degree of protection IP56

5.4 Vibration IEC 60945 Ed.4

6 UNIT COLOR



N9.5

PACKING LIST

03HZ-X-9851 -0 1/1

RSB-137-119-E

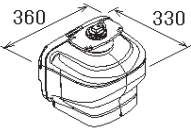
A-1

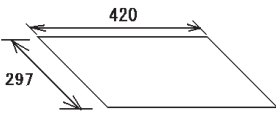
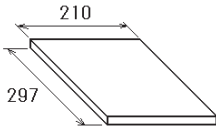
NAME	OUTLINE	DESCRIPTION/CODE No.	Q' TY
ユニット UNIT			
空中線本体部 SCANNER UNIT		RSB-137-119 000-033-451-00	1
予備品 SPARE PARTS			
予備品 SPARE PARTS		SP03-19101 001-477-060-00	1
工事材料 INSTALLATION MATERIALS			
工事材料 INSTALLATION MATERIALS		CP03-37101 001-426-290-00	1
図書 DOCUMENT			
型紙 TEMPLATE		C32-00703-* 7/11 000-167-459-1*	1
装備要領書(英) INSTALLATION MANUAL (EN)		IME-36680-* 000-193-441-1*	1

(略図の寸法は、参考値です。 DIMENSIONS IN DRAWING FOR REFERENCE ONLY.)

C3668-Z01-A

表2 TABLE 2

誘射器 PATIATOR	XN10A	XN12A	XN13A
空中線長 (A)(mm) ANTENNA LENGTH	1036±10	1255±10	1795±10
回転安全距離 (B)(mm) ANTENNA CLEARANCE	1200	1400	1940
質量 (kg±10%) MASS	20	21	23

表1 TABLE 1

寸法区分 (mm) DIMENSION	公差 (mm) TOLERANCE
L ≤ 50	±1.5
50 < L ≤ 100	±2.5
100 < L ≤ 500	±3
500 < L ≤ 1000	±4
1000 < L ≤ 2000	±5

4-M12 取付穴 (換装用) 有効ネジ深さ18
FIXING HOLES (FOR REMOUNT) DEPTH:18

回転中心
CENTER OF ROTATION

船首方向
BOW

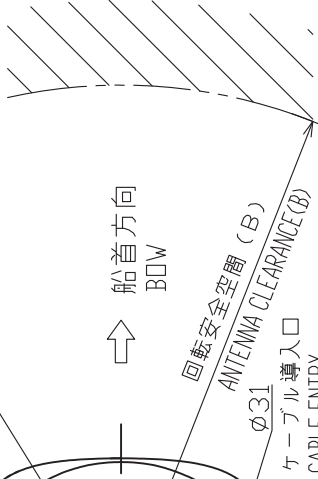

取付穴 (標準) 有効ネジ深さ: 18
4-M12
FIXING HOLES (STANDARD) DEPTH:18

空中線長 (A) ANTENNA LENGTH (A)

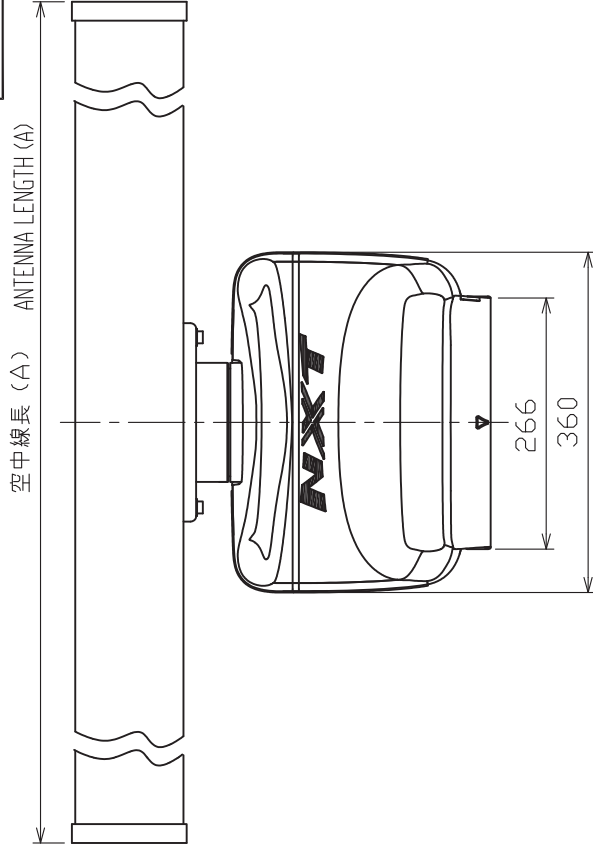
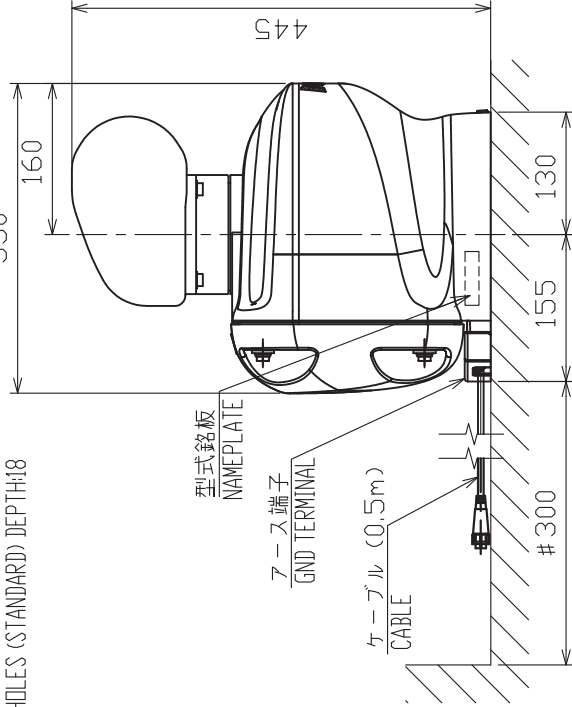

- 注記 1) 指定外寸法公差は表1による。
2) #印寸法は最小サービス空間寸法とする。
3) 取付はM12寸切ボルトを使用のこと。
- NOTE 1. TABLE 1 INDICATES TOLERANCE OF DIMENSIONS WHICH IS NOT SPECIFIED.
2. # MINIMUM SERVICE CLEARANCE.
3. USE M12 STUD BOLT FOR FIXING THE UNIT.

DRAWN	2/Feb/2017	T. YAMASAKI	TITLE	RSB-137
CHECKED	2/Feb/2017	H. MAKI	名称	空中線部
APPROVED	2/Feb/2017	H. MAKI	DRSGA-NXT	外寸図
SCALE	1/8	表2参照 TABLE 2	NAME	ANTENNA UNIT
DWG.No.	C3668-G01-A	REF.No.	03-194-300G-1	OUTLINE DRAWING

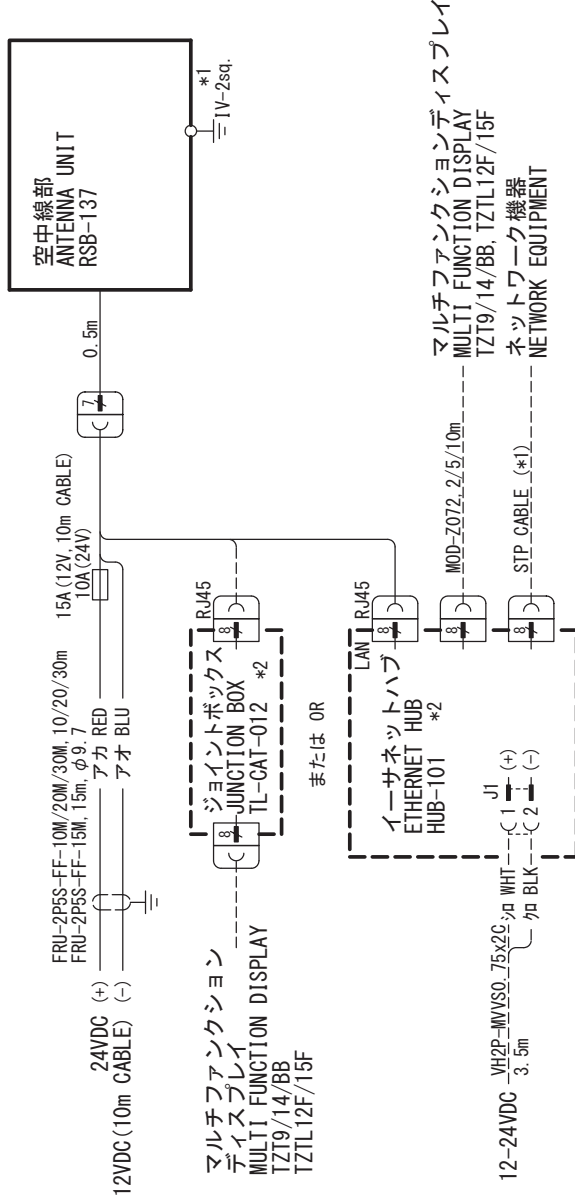

注記

- * 1) 造船所手配。
- * 2) オプション。

NOTE

- *1: SHIPYARD SUPPLY.
- *2: OPTION.

DRAWN	3/Feb/2017	T. YAMASAKI	TITLE	DRS6A-NXT
CHECKED	3/Feb/2017	H. MAKI	名称	レーダーセンサー
APPROVED	3/Feb/2017	H. MAKI	NAME	相互結線図
SCALE		kg		RADAR SENSOR
DWG. No.	C3668-C01-A	REF. No.	03-194-6011-0	INTERCONNECTION DIAGRAM

Declaration of Conformity

[DRS6A-NXT]

- Bulgarian (BG)** С настоящото Furuno Electric Co., Ltd. декларира, че гореспоменат тип радиосъоръжение е в съответствие с Директива 2014/53/ЕС.
Цялостният текст на ЕС декларацията за съответствие може да се намери на следния интернет адрес:
- Spanish (ES)** Por la presente, Furuno Electric Co., Ltd. declara que el tipo de equipo radioeléctrico arriba mencionado es conforme con la Directiva 2014/53/UE.
El texto completo de la declaración UE de conformidad está disponible en la dirección Internet siguiente:
- Czech (CS)** Tímto Furuno Electric Co., Ltd. prohlašuje, že výše zmíněné typ rádiového zařízení je v souladu se směrnicí 2014/53/EU.
Úplné znění EU prohlášení o shodě je k dispozici na této internetové adrese:
- Danish (DA)** Hermed erklærer Furuno Electric Co., Ltd., at ovennævnte radioudstyr er i overensstemmelse med direktiv 2014/53/EU.
EU-overensstemmelseserklæringens fulde tekst kan findes på følgende internetadresse:
- German (DE)** Hiermit erkläre die Furuno Electric Co., Ltd., dass der oben genannte Funkanlagentyp der Richtlinie 2014/53/EU entspricht.
Der vollständige Text der EU-Konformitätserklärung ist unter der folgenden Internetadresse verfügbar:
- Estonian (ET)** Käesolevaga deklareerib Furuno Electric Co., Ltd., et ülalmainitud raadioseadme tüüp vastab direktiivi 2014/53/EL nõuetele.
ELi vastavusdeklaratsiooni täielik tekst on kättesaadav järgmisel internetiaadressil:
- Greek (EL)** Με την παρούσα η Furuno Electric Co., Ltd., δηλώνει ότι ο προαναφερθέντας ραδιοεξοπλισμός πληροί την οδηγία 2014/53/ΕΕ.
Το πλήρες κείμενο της δήλωσης συμμόρφωσης ΕΕ διατίθεται στην ακόλουθη ιστοσελίδα στο διαδίκτυο:
- English (EN)** Hereby, Furuno Electric Co., Ltd. declares that the above-mentioned radio equipment type is in compliance with Directive 2014/53/EU.
The full text of the EU declaration of conformity is available at the following internet address:
- French (FR)** Le soussigné, Furuno Electric Co., Ltd., déclare que l'équipement radioélectrique du type mentionné ci-dessus est conforme à la directive 2014/53/UE.
Le texte complet de la déclaration UE de conformité est disponible à l'adresse internet suivante:
- Croatian (HR)** Furuno Electric Co., Ltd. ovime izjavljuje da je gore rečeno radijska oprema tipa u skladu s Direktivom 2014/53/EU.
Cjeloviti tekst EU izjave o sukladnosti dostupan je na sljedećoj internetskoj adresi:
- Italian (IT)** Il fabbricante, Furuno Electric Co., Ltd., dichiara che il tipo di apparecchiatura radio menzionato sopra è conforme alla direttiva 2014/53/UE.
Il testo completo della dichiarazione di conformità UE è disponibile al seguente indirizzo Internet:
- Latvian (LV)** Ar šo Furuno Electric Co., Ltd. deklarē, ka augstāk minēts radioiekārta atbilst Direktīvai 2014/53/ES.
Pilns ES atbilstības deklarācijas teksts ir pieejams šādā interneta vietnē:

Lithuanian (LT)	Aš, Furuno Electric Co., Ltd., patvirtinu, kad pirmiau minėta radijo įrenginių tipas atitinka Direktyvą 2014/53/ES. Visas ES atitikties deklaracijos tekstas prieinamas šiuo interneto adresu:
Hungarian (HU)	Furuno Electric Co., Ltd. igazolja, hogy fent említett típusú rádióberendezés megfelel a 2014/53/EU irányelvnek. Az EU-megfelelőségi nyilatkozat teljes szövege elérhető a következő internetes címen:
Maltese (MT)	B'dan, Furuno Electric Co., Ltd., niddikjara li msemmija hawn fuq-tip ta' tagħmir tar-radju huwa konformi mad-Direttiva 2014/53/UE. It-test kollu tad-dikjarazzjoni ta' konformità tal-UE huwa disponibbli f'dan l-indirizz tal-Internet li ġej:
Dutch (NL)	Hierbij verklaar ik, Furuno Electric Co., Ltd., dat het hierboven genoemde type radioapparaat conform is met Richtlijn 2014/53/EU. De volledige tekst van de EU-conformiteitsverklaring kan worden geraadpleegd op het volgende internetadres:
Polish (PL)	Furuno Electric Co., Ltd. niniejszym oświadczam, że wyżej wymieniony typ urządzenia radiowego jest zgodny z dyrektywą 2014/53/UE. Pełny tekst deklaracji zgodności UE jest dostępny pod następującym adresem internetowym:
Portuguese (PT)	O(a) abaixo assinado(a) Furuno Electric Co., Ltd. declara que o mencionado acima tipo de equipamento de rádio está em conformidade com a Diretiva 2014/53/UE. O texto integral da declaração de conformidade está disponível no seguinte endereço de Internet:
Romanian (RO)	Prin prezenta, Furuno Electric Co., Ltd. declară că menționat mai sus tipul de echipamente radio este în conformitate cu Directiva 2014/53/UE. Textul integral al declarației UE de conformitate este disponibil la următoarea adresă internet:
Slovak (SK)	Furuno Electric Co., Ltd. týmto vyhlasuje, že vyššie spomínané rádiové zariadenie typu je v súlade so smernicou 2014/53/EÚ. Úplné EÚ vyhlásenie o zhode je k dispozícii na tejto internetovej adrese:
Slovenian (SL)	Furuno Electric Co., Ltd. potrjuje, da je zgoraj omenjeno tip radijske opreme skladen z Direktivo 2014/53/EU. Celotno besedilo izjave EU o skladnosti je na voljo na naslednjem spletnem naslovu:
Finnish (FI)	Furuno Electric Co., Ltd. vakuuttaa, että yllä mainittu radiolaitetyyppi on direktiivin 2014/53/EU mukainen. EU-vaatimusten mukaisuusvakuutuksen täysimittainen teksti on saatavilla seuraavassa internetosoitteessa:
Swedish (SV)	Härmed försäkrar Furuno Electric Co., Ltd. att ovan nämnda typ av radioutrustning överensstämmer med direktiv 2014/53/EU. Den fullständiga texten till EU-försäkran om överensstämmelse finns på följande webbadress:

Online Resource

http://www.furuno.com/en/support/red_doc

ECF

(Elemental Chlorine Free)

The paper used in this manual
is elemental chlorine free.

FURUNO ELECTRIC CO., LTD.

9-52 Ashihara-cho,
Nishinomiya, 662-8580, JAPAN

• FURUNO Authorized Distributor/Dealer

All rights reserved. Printed in Japan

Pub. No. IME-36680-B2

(ETMI) DRS6A-NXT

A : APR. 2017

B2 : APR. 03, 2018



0 0 0 1 9 3 4 4 1 1 1